

VG/5624

Place Shaping Team
South Norfolk Council
Thorpe Lodge
1 Yarmouth Road
Norwich
NR7 0DU

7th March 2023

Dear Sir/Madam,

RE: South Norfolk Village Clusters Housing Allocations Plan (Reg 19 Presubmission Draft)

This representation presents details in respect of questions 5 and 6 of the accompanying representation form. For completeness, the questions have been extracted in **bold** with our responses below each question.

5. Please give details of why you consider the Local Plan is not legally compliant or is unsound or fails to comply with the duty to co-operate. Please be as precise as possible. If you wish to support the legal compliance with the duty to co-operate, please also use this box to set out your comments.

We consider that the plan is unsound for the reasons detailed below.

The District Council will be aware that Woods Hardwick Planning Ltd made a Call for Sites submission on behalf of our client, Gosford Ltd in November 2016 to promote our client's site for allocation of up to 33 dwellings and the site has been assessed as part of the draft Plan under site reference SN0594. On behalf of our client, we also submitted representations to the emerging Greater Norwich Local Plan at the Regulation 18 stage in March 2020; Regulation 19 stage in March 2021 and Regulation 18 Consultation on the Draft Village Clusters Housing Allocations Plan in July 2021.

We note that our client's site has not been carried forward as an allocated site for reasons set out in the Site Assessment document. The overall conclusion noted in the assessment as follows:

The site is considered to be UNREASONABLE as an allocated site. Access to the site is gained via the A140 where accessing services and facilities would require crossing the road, which is considered to be unsuitable and unsafe. The A140 is a Corridor of Movement where stopping/turning movements would be unacceptable. Furthermore, development of the site is also considered to have a landscape impact as it slopes down towards the River Valley. It is considered that these issues cannot be mitigated against.

It was noted that the material in support of the previous consultation exhibition describes under 'Identifying Suitable Sites' how the consultation on Preferred, Shortlisted and Rejected Sites provides an opportunity for the public or other stakeholders (including developers, site promoters and agents) to put forward further information that may change the conclusions on particular sites, for instance further evidence that an unsuitable site could overcome an identified constraint.

BEDFORD : HEAD OFFICE
15-17 Goldington Road
Bedford MK40 3NH
T : +44 (0) 1234 268862

BIRMINGHAM
Fort Dunlop, Fort Parkway
Birmingham B24 9FD
T : +44 (0) 0121 803 6070

LONDON
The Harley Building
77 New Cavendish Street
London W1W 6XB
T: +44(0) 204 548 1104

ONLINE
planning@woodshardwick.com
woodshardwick.com



Subsequently to this, we included evidence as part of consultations in respect of the latter.

We note that the Council's Site Assessment Forms for the Newton Flotman and Swainsthorpe Village Cluster were completed on 20 August 2020. Our client has since undertaken further technical work related to highways and access and landscape visual appraisal, which we consider addresses the above reason for rejection.

A Transport Technical note dated July 2021, which was submitted at the previous consultation provided a summary of technical work undertaken with discussions with Norfolk County Council Highways Authority on a proposed access solution for the site. The note presented confirmation that the County Council considered the proposal acceptable in principle.

In addition, a Landscape and Visual Appraisal was submitted to appraise the likely landscape and visual effects for a development of up to 30 residential units. The appraisal concludes that overall, the proposed scheme would comprise a modest addition to the village in a location that already feels part of the village and is already developed. It further concludes that the proposed scheme would fit in with the existing character and form of the settlement and would have a very limited effect on the landscape or visual amenity beyond the site itself. We therefore consider that the Site Score should change from Amber to Green under these headings.

We note from the Council's own assessment under the heading of Overall Landscape Assessment, that although development may impact upon the Tas river valley characteristics, this could be mitigated through design. We would highlight that this is at odds with the Council's overall conclusion that impacts cannot be mitigated against.

Notwithstanding, we disagree with the Council's reason for rejection on landscape grounds. The site does slope gently towards the river but this is not a valid reason for rejection. The woodland beyond the river provides containment in the wider landscape and there are no public viewpoints in this location that would be affected.

The aforementioned resulted in adjustments to the initial sketch layout which was also submitted as part of the previous stage of the local plan process, showing provision for pedestrian access route to the north eastern corner of the site; an attenuation basin to accommodate and treat surface water discharge to the watercourse.

Suitability

We consider that Newton Flotman can and should accommodate additional housing to that proposed under the Preferred Site reference SN4024 and that our client's site should be allocated for such provision. Newton Flotman is identified as a Service Village in the adopted Joint Core Strategy for Broadland, Norwich and South Norfolk (2014), which are noted at paragraph 6.60 of the Core Strategy as having a good level of services/facilities.

Furthermore, the draft Village Clusters Housing Allocations Plan describes at section 27 under the heading 'Services and Community Facilities' how Newton Flotman has a good range of services and facilities, including GP surgery, primary school and pre-school, village hall, recreational areas and allotments. It is also noted that there is a restaurant to the south of the village and local employment at the animal feed mill to the south of the river, whilst the village also possesses a good direct link via the A140 to Norwich and Long Stratton and there are regular bus services. The village therefore represents a sustainable location for additional housing development.

We would also highlight that unlike the other sites assessed for Newton Flotman & Swainsthorpe which are all 'Greenfield' sites, our client's site is already partially developed. There are two residential buildings on site, a disused swimming pool and a number of single storey shed structures



as well as an open field and paddock area. We also note that outline planning permission was granted on an undeveloped part of the site on Land South of Jaylyn in April 2017 with subsequent reserved matters approvals in April 2018 for 2 Self/Custom Build Dwellings and Garages. The parts of the site already developed represent brownfield land, development of which is encouraged by national planning policy.

We consider it important to reinforce the following merits of the sites:

- The site can accommodate up to 30 new dwellings
- The transport technical note has been discussed at a County Council Development Team meeting and the associated email correspondence from the County Council dated 11 May 2021 confirms that the proposal is considered to be acceptable in principle, subject to a Stage 1 Safety Audit and future detailed design. We consider that this technical work addresses the previous NCC Highways comments in blue on the site assessment form and the Site Score should change from Red to Green on this basis.
- The site has access to a good range of services and facilities and safe pedestrian access across the A140 can be facilitated.
- The site can exclude development from part of the site falling within flood zone 3b and the provision of an attenuation basin will serve as a SuDS feature.
- The landscape and townscape appraisal concludes that overall, the proposed scheme would comprise a modest addition to the village in a location that already feels part of the village and is already developed. It further concludes that the proposed scheme would fit in with the existing character and form of the settlement and would have a very limited effect on the landscape or visual amenity beyond the site itself. We therefore consider that the Site Score should change from Amber to Green under these headings.

Public benefits

Under the heading of Achievability, the site assessment asks: Are there any associated public benefits proposed as part of delivery of the site, to which the assessment currently answers No.

Following discussions with Newton Flotman Parish Council, we would propose that as part of a residential development scheme pedestrian access is provided through our client's site to the north east corner boundary with adjoining Shotesham Estates land to assist with facilitating access through to Smockmill Common. On this basis, we would propose that reference to such provision would be included in any residential allocation for the site.

Smockmill Common is a local nature reserve and popular place for recreation. However, access to the Common from the village is currently via a circular route using Cargate Lane, which is relatively narrow with no footways. As such, the existing route is not attractive for pedestrian use and it is therefore an objective of the District and Parish Councils to try and secure a more convenient route for pedestrians accessing the Common from the Village.

In addition to providing access through our client's site, we have further indicated to the Parish Council that, subject to details and cost, our client would in principle be prepared to contribute to the cost of the physical works of providing access through the adjoining land, including the provision of a pedestrian bridge across the river.

We consider that the above represents an important public benefit, which other sites in Newton Flotman would not be in a position to deliver and, on this basis, the answer to the question should change from No to Yes.



Conclusion

Having regard to the aforementioned we consider the site is reasonable for an allocation. Considering this is not the conclusion, the council has made, we therefore consider that the plan is unsound.

In addition to the above considerations, we note that both the Preferred Site Reference SN4024 and Shortlisted Site Reference SN4025 for Newton Flotman are noted as being subject to achieving safe and suitable access in the Council's Site Assessment Forms, whereas access to our client's site is readily available with an access solution which is considered to be acceptable in principle by the County Highways Authority.

Question 6: Please set out the modification(s) you consider necessary to make the Local Plan legally compliant and sound, in respect of any legal compliance or soundness matters you have identified at 5 above. (Please note that non-compliance with the duty to co-operate is incapable of modification at examination). You will need to say why each modification will make the Local Plan legally compliant or sound. It will be helpful if you are able to put forward your suggested revised wording of any policy or text. Please be as precise as possible.

We consider section 27 be modified to include our client's site and update on the settlement limit.

For the reasons noted above, we consider that that our client's site reference SN0594 should be allocated for up to 30 residential dwellings and that the limit of the main built form of the settlement should at least be extended to include the site. Furthermore, we consider that the A140 should not form the settlement limit to the east of the village but rather the limit should be extended to include the existing development to the east of the A140. Residential properties in this location clearly form part of the settlement pattern of the village and would form a logical extension to the settlement limit. We trust the District Council will have due regard to these representations in its further consideration of the drafting of the Housing Allocations Plan and look forward to reviewing the Council's progress on the next stage Plan in due course.

Yours sincerely

For and on behalf of WOODS HARDWICK PLANNING

Vanessa Gordon
Planner

Enc: Transport Technical Note; Landscape and Visual appraisal; County Council agreement in principle

cc:

Appendix 1- Transport Technical Note (July 2021)

PROJECT TITLE: Ipswich Road, Newton Flotman
PROJECT JOB NO: 17901
REPORT REF: 17901/TTN/JULY21
DATE: 23/07/2021
PREPARED BY: GBR

Ipswich Road, Newton Flotman: Transport Technical Note (JULY 2021)

Introduction

1. This Transport Technical Note (TTN) has been prepared by Woods Hardwick Infrastructure LLP in relation to a proposed residential development on land to the east of the A140 Ipswich Road, Newton Flotman, Norfolk. A Site Location Plan is included within **Appendix A**.
2. The current proposals comprise the development of the site to provide up to 30 residential dwellings. A Proposed Site Masterplan is included in **Appendix B**.
3. The purpose of this Note is to provide an update on the outcome of discussions with Norfolk County Council (NCC) Highway Authority with regard to the Highway related implications of the proposals.
4. The Note summarises the discussions held with NCC following submission of Woods Hardwick's November 2020 TTN, which is contained in **Appendix C**. This report should therefore be read in conjunction with the November 2020 document.
5. Correspondence between Woods Hardwick and the Highway Authority via email following submission of the November 2020 TTN is contained in **Appendix D**. From the correspondence it can be appreciated that in the Highway Authority's initial response they directed Woods Hardwick to a study that was undertaken on behalf of the Highway Authority in 2017 the purpose of which was to explore mitigation options to improve the operation of the existing A140/Flordon Road junction.
6. Within the correspondence the Highway Authority advised that if the applicant were to design a scheme that provides back-to-back right turn lanes and addresses HGV concerns then they would be willing to undertake a further review. It was also requested that a staggered pedestrian crossing facility is provided.
7. As such Woods Hardwick prepared a revised Site Access drawing a copy of which is included within **Appendix E**. The revised drawing demonstrates that a right turn lane access to the proposed development site can be provided along with a right turn lane for southbound traffic on the A140 to turn into Flordon Road. The drawing also shows a staggered pedestrian crossing further to the south.

8. Following submission of the revised Site Access drawing the Highway Authority confirmed, that the revised proposals were discussed at a development team meeting and considered acceptable in principle subject to a Stage 1 Road Safety Audit. The Highway Officer also noted that they would have no objection with this information being shared with the District Council hence the preparation of this TTN.
9. At such time as a planning application is prepared, it would be supported by a Transport Assessment that includes junction modelling of the proposed mitigation works and the aforementioned Stage 1 Road Safety Audit.
10. To summarise the above, following discussions between the applicant and the Highway Authority, it has been agreed in principle that a suitable access to the proposed development can be achieved.

Appendix A

Site Location Plan



1. Contractors must check all dimensions on site. Only figured dimensions are to be worked from. Discrepancies must be reported to the Architect or Engineer before proceeding. © This drawing is copyright
2. Reproduced from OS Sitemap ® by permission of Ordnance Survey® on behalf of The Controller of Her Majesty's Stationery Office. © Crown copyright 2008. All rights reserved. Licence number 100007126.



Revision	Description	Drawn	Checked	Date						
	Preliminary	■	Information	■	Tender	■	Construction	■	As Built	■

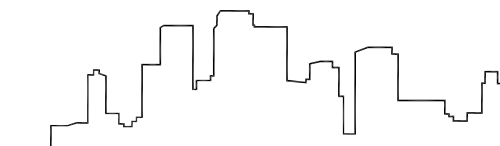

Woods Hardwick
Architects, Engineers and Development Consultants

15-17 Goldington Road
Bedford
MK40 3NH
United Kingdom
T. +44 (0)1234 268862
F. +44 (0)1234 353034
mail@woodshardwick.com
www.woodshardwick.com

Title **Newton Flotman
Ipswich Road - A140**

Details **Site Location Plan**

Saved : h\projects

Scale **1:1250@A3** Date **NOV 2016** Drawn **SA** Chk **TJF**

17746/1000

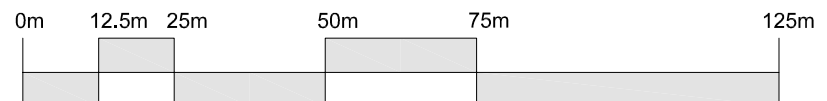

1:1250

Appendix B

Site Masterplan

- Contractors must check all dimensions on site. Only figured dimensions are to be worked from. Discrepancies must be reported to the Architect or Engineer before proceeding. © This drawing is copyright
- Reproduced from OS Sitemap® by permission of Ordnance Survey® on behalf of The Controller of Her Majesty's Stationery Office. © Crown copyright 2008. All rights reserved. Licence number 100007126.



- Key -
- Existing Tree
 - Existing Hedgerow
 - Existing Development
 - Proposed Development
 - Proposed Private Drive
 - Proposed Adopted Road
 - Proposed Tree
 - Proposed Landscaped Buffer
 - Proposed Affordable Development

A LAYOUT UPDATED TO INCORPORATE LANDSCAPE AND ACCESS COMMENTS SA TF 14.12.2020

Revision	Description	Drawn	Checked	Date
Preliminary	Information	Tender	Construction	As Built

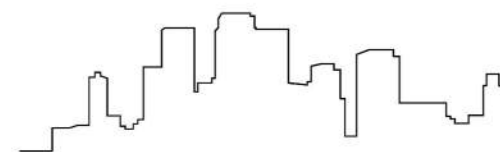

Woods Hardwick
Architects, Engineers and Development Consultants

Title **NEWTON FLOTMAN
IPSWICH ROAD - A140**

15-17 Goldington Road
Bedford
MK40 3NH
United Kingdom
T. +44 (0)1234 268862
F. +44 (0)1234 353034
mail@woodshardwick.com
www.woodshardwick.com

Details **ILLUSTRATIVE SKETCH LAYOUT**

Scale 1:1250@A3 Date NOV 2016 Drawn SA Chk TJF

Please consider the environment before printing this drawing

17746/1001A

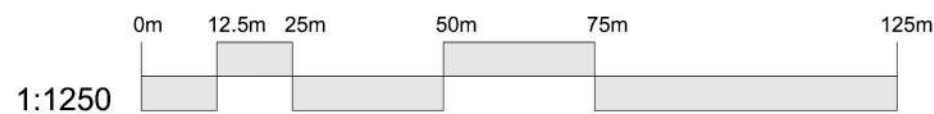

1:1250

Appendix C

Transport Technical Note November 2020

PROJECT TITLE: Ipswich Road, Newton Flotman
PROJECT JOB NO: 17901
REPORT REF: 17901/TTN/NOV20.
DATE: 27/11/20
PREPARED BY: GBR

Ipswich Road, Newton Flotman: Transport Technical Note (November 2020)

Introduction

1. This Transport Technical Note has been prepared by Woods Hardwick Infrastructure LLP in relation to a proposed residential development on land to the east of the A140 Ipswich Road, Newton Flotman, Norfolk. A Site Location Plan is included within **Appendix A**.
2. The current proposals comprise the development of the site to provide up to 33 residential dwellings. A Proposed Site Masterplan is included in **Appendix B**.
3. The purpose of this Note is to facilitate discussions with Norfolk County Council (NCC) Highway Authority with regard to the Highway related implications of the proposals. The Note summarises previous discussions and provides further information which seeks to address comments previously received from the Highway Authority in relation to the potential impacts of the proposals.
4. A Pre-Application submission was made to South Norfolk District Council in 2017; the consultation response included advice received from NCC in their role as local Highway Authority.
5. NCC's response to the submission noted that, in their view, the proposals submitted at the time did not comply with the requirements of Policy DM 3.11 of the South Norfolk Local Plan.
6. In light of the above, the potential offsite highway impact has been reviewed in greater detail and a scheme of potential improvement works has been developed in order to assist in ensuring compliance with Policy DM 3.11.
7. This Note summarises the impact assessment that has been undertaken in relation to the proposed site access and describes the proposed highway improvement works which have been subject to a Stage 1 Road Safety Audit.
8. The proposed improvement works are considered to facilitate safe access to the site for vehicles without compromising the free flow of traffic on the existing road network. The proposals also include a commitment to improved pedestrian connectivity to and from the site, subject to the requirements of the Highway Authority.

Impact Assessment

9. A copy of the Site Access proposals are shown on the Site Access Drawing, a copy of which is included as **Appendix C**. It is proposed to incorporate a right turn lane for vehicles turning right to enter the site so as to ensure that these vehicles would not momentarily disrupt the free flow of through traffic.
10. In order to facilitate a capacity assessment at the proposed junction, traffic counts were undertaken along Ipswich Road between 3/7/17 -16/7/17.
11. The peak hour data from the traffic count from the busiest day for which data was recorded (5/7/17) has been used with network growth to 2026 added.
12. It is anticipated that the growth rates used will be an over-estimate due to the increased prevalence of homeworking resulting from the COVID-19 pandemic. The growth rates used which have been extracted from the Temprow Database are presented below.

AM Growth (2017 -2026): 1.0886

PM Growth (2017-2026): 1.0905

13. The anticipated site generated traffic flows have been calculated using trip rate data extracted from the TRICS database. The trip rates used and the resultant trip generations are presented in the table below; the full TRICS data is provided in **Appendix D**.

Peak Hour	Trip Rate (per dwelling)		Trip Generation (based on 33 dwellings)	
	Arrivals	Departures	Arrivals	Departures
AM (08:00-09:00)	0.155	0.407	6	14
PM (17:00-18:00)	0.359	0.223	12	8

14. The junction has been modelled using the industry standard Junctions 9 software. The capacity of a priority junction is expressed in terms of its ratio of flow to capacity value (RFC). A junction is considered to operate within its capacity when an RFC is below 1.0.
15. The results of the capacity assessment are shown in the table below with the full output included within **Appendix E**, from which it can be concluded that the proposed revised site access junction arrangement would operate well within its capacity without causing delay to through traffic.

	AM				PM			
	Queue (PCU)	Delay (s)	RFC	LOS	Queue (PCU)	Delay (s)	RFC	LOS
Do Something 2026								
Stream B-C	0.0	6.29	0.02	A	0.0	6.55	0.01	A
Stream B-A	0.0	8.28	0.00	A	0.0	8.84	0.00	A
Stream C-AB	0.0	5.77	0.00	A	0.0	6.12	0.01	A

Highway Safety

16. The site access proposals have been designed such that they provide a suitable point of entry/exit for the site while also assisting in increasing highway safety in the locality.
17. It is proposed that the northern most entry point from Flordon Road to Ipswich Road is closed off such that the road would only provide access to the existing businesses. This would be beneficial in terms of reducing the number of accesses onto Ipswich Road thereby assisting in enhancing highway safety.
18. The proposals also allow for the provision of a dedicated right turn lane for vehicles seeking to enter the site. The right turn lane has capacity for five vehicles meaning that turning vehicles would not affect the free flow of traffic along Ipswich Road.
19. The proposed access arrangements and highway improvement works have been subject to an independent Stage 1 Road Safety Audit. The Audit raised three minor issues which have been addressed within the latest proposals. The Safety Audit and subsequent confirmation from the auditor that the revised proposals address the concerns raised is included within **Appendix F**.

Compliance with Policy DM 3.11

20. As noted within the introduction to this report, in response to the original Pre-Application submission the Highway Authority advised that they would not be supportive of the proposals on the basis that it was their view that the proposals were not compliant with Policy DM 3.11 of the South Norfolk Local Plan.
21. Since the original advice was received from the Highway Authority further work has been undertaken to ensure compliance with Policy DM 3.11. This section of the report examines each strand of the Policy and confirms how the proposals are in compliance. For ease of reference the Policy is reproduced below.

(1) On all sites development will not be permitted that endangers highway safety or the satisfactory functioning of the highway network.

(2) Planning permission will be granted for development involving the formation or intensified use of a direct access onto a Corridor of Movement providing it would not:

(a) Prejudice the safe and free flow of traffic or planned proposals for sustainable transport initiatives along the Corridor of Movement;

(b) Be practical to gain access from the site to the Corridor of Movement via a secondary road; and

(c) Facilitate the use of the Corridor of Movement for short local journeys.

22. Part 1 of the Policy is addressed by virtue of the fact that an Independent Stage 1 Road Safety Audit has determined that the proposals do not raise any safety concerns.
23. Part 2 (a) of the Policy is satisfied through the proposed provision of a dedicated right turn lane for vehicles seeking to access the site. The capacity assessment that has been undertaken confirms this to be the case. The applicant is not aware of any proposed sustainable transport initiatives in the area that would be compromised by the proposals.

24. Part 2 (b) is addressed on the basis that there are no secondary roads between the site and Ipswich Road.
25. Part 2 (c) is addressed on the basis that the existing settlement is well within walking distance of the site and there is therefore no specific reason for residents of the site to drive short journeys using the Corridor of Movement.
26. The applicant would welcome a discussion with the Highway Authority in relation to any pedestrian crossing facilities that could be incorporated into the proposals to assist ensuring safe and convenient access to the existing village. It is noted that existing residents are required to cross the road in order to access southbound bus services and the principle of pedestrians crossing the road is therefore well established.
27. Further to the above, through recent discussions with the Parish Council we are aware that it is an objective of theirs to secure a public footpath route through the proposed development site to connect to Smockhill Common. The applicant is willing to assist with the provision of this route as part of residential redevelopment of the site, which could potentially be provided in conjunction with improved pedestrian facilities as alluded to above.

Summary and Conclusion

28. This Note has been prepared by Woods Hardwick Infrastructure LLP in relation to a proposed residential development comprising up to 33 residential dwellings at a site on the eastern side of Ipswich Road, Newton Flotman, Norfolk.
29. The main purpose of the Note is to set out the site access arrangements in terms of highway capacity and safety. Following previous Pre-Application discussions with the Highway Authority, the Note focuses on confirming compliance with Policy DM 3.11 of the South Norfolk Local Plan.
30. A junction capacity assessment has been undertaken which confirms that the proposals would not lead to a delay of through traffic. Although not strictly necessary in junction capacity terms, the access proposals include a dedicated right turn lane in order to ensure that turning vehicles would not disrupt the free movement of traffic.
31. The proposals have been subject to an Independent Stage 1 Road Safety Audit; following minor amendments to the original proposals the Safety Auditor has confirmed that the current proposals address the initial concerns raised.
32. It is confirmed that the applicant would welcome a discussion with the Highway Authority in relation to the provision of a formal pedestrian crossing over Ipswich Road if considered appropriate by the Highway Authority.
33. On the basis of the above it is concluded that the current proposals are fully compliant with the requirements of Policy DM 3.11 of the South Norfolk Local Plan and should therefore be supported through the planning process in terms of highways and transportation.
34. Notwithstanding the above, discussion with the Highway Authority in relation to any of the above would be welcomed.

Appendix A

Site Location Plan



1. Contractors must check all dimensions on site. Only figured dimensions are to be worked from. Discrepancies must be reported to the Architect or Engineer before proceeding. © This drawing is copyright
2. Reproduced from OS Sitemap ® by permission of Ordnance Survey® on behalf of The Controller of Her Majesty's Stationery Office. © Crown copyright 2008. All rights reserved. Licence number 100007126.



Revision	Description	Drawn	Checked	Date						
	Preliminary	■	Information	■	Tender	■	Construction	■	As Built	■

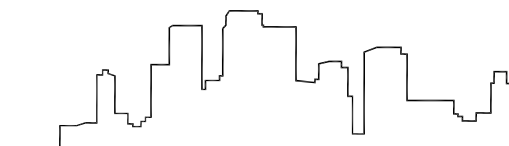

Woods Hardwick
Architects, Engineers and Development Consultants

15-17 Goldington Road
Bedford
MK40 3NH
United Kingdom
T. +44 (0)1234 268862
F. +44 (0)1234 353034
mail@woodshardwick.com
www.woodshardwick.com

Title **Newton Flotman
Ipswich Road - A140**

Details **Site Location Plan**

Saved : h\projects

Scale **1:1250@A3** Date **NOV 2016** Drawn **SA** Chk **TJF**

17746/1000

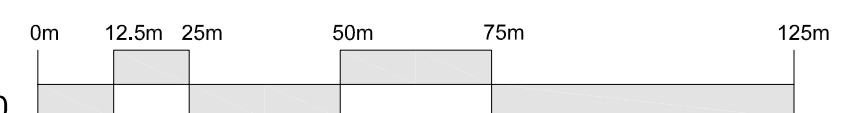

1:1250

Appendix B

Site Masterplan

- Contractors must check all dimensions on site. Only figured dimensions are to be worked from. Discrepancies must be reported to the Architect or Engineer before proceeding. © This drawing is copyright
- Reproduced from OS Sitemap ® by permission of Ordnance Survey® on behalf of The Controller of Her Majesty's Stationery Office. © Crown copyright 2008. All rights reserved. Licence number 100007126.



Key -

- Existing Tree
- Existing Hedgerow
- Existing Development
- Proposed Development
- Proposed Private Drive
- Proposed Adopted Road
- Proposed Tree
- Proposed Landscaped Buffer
- Proposed Affordable Development

ACCOMMODATION MIX:

PRIVATE:

TYPE	BEDS	NO.
1790	4B	1
1719	4B	2
1321	4B	5
1253	3B	2
1036	3B	2
998	3B	4
792	2B	6
TOTAL:		22 - (67%)

AFFORDABLE

966	3B	3
894	2B	4
603/486	1B	4
TOTAL:		11 - (33%)
GRAND TOTAL:		33

Revision	Description	Drawn	Checked	Date
Preliminary	Information	Tender	Construction	As Built



Woods Hardwick
Architects, Engineers and Development Consultants

Title **NEWTON FLOTMAN
IPSWICH ROAD - A140**

Details **ILLUSTRATIVE SKETCH LAYOUT**

Scale 1:1250@A3 Date NOV 2016 Drawn SA Chk TJF

15-17 Goldington Road
Bedford
MK40 3NH
United Kingdom
T. +44 (0)1234 268862
F. +44 (0)1234 353034
mail@woodshardwick.com
www.woodshardwick.com



1:1250

Appendix C

Site Access Drawing

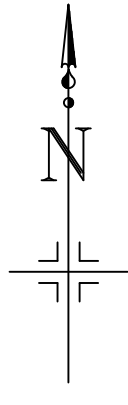



NOTES

1. CONTRACTORS MUST CHECK ALL DIMENSIONS ON SITE. ONLY FIGURED DIMENSIONS ARE TO BE WORKED FROM. DISCREPANCIES MUST BE REPORTED TO THE ARCHITECT OR ENGINEER BEFORE PROCEEDING. © THIS DRAWING IS COPYRIGHT.
2. REPRODUCED FROM OS SITEMAP © BY PERMISSION OF ORDNANCE SURVEY® ON BEHALF OF THE CONTROLLER OF HER MAJESTY'S STATIONERY OFFICE. © CROWN COPYRIGHT 2008. ALL RIGHTS RESERVED. LICENCE NUMBER 100007126.
3. UNTIL TECHNICAL APPROVAL HAS BEEN OBTAINED FROM THE RELEVANT AUTHORITIES, ALL DRAWINGS ARE ISSUED AS PRELIMINARY AND NOT FOR CONSTRUCTION. SHOULD THE CONTRACTOR COMMENCE SITE WORK PRIOR TO APPROVAL BEING GIVEN IT IS ENTIRELY AT THEIR OWN RISK.
4. WOODS HARDWICK CANNOT ACCEPT LIABILITY FOR ANY DISCREPANCIES IN TERMS OF COORDINATES OR ANY OTHER INFORMATION DECIPHERED FROM DWG'S.

SAFETY HEALTH AND ENVIRONMENTAL

THERE ARE NO EXCEPTIONAL RISKS ASSOCIATED WITH THESE WORKS. REFER TO THE DESIGNERS RISK ASSESSMENT FOR THE FULL ASSESSMENT OF RISKS.

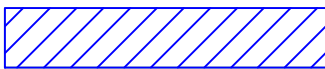
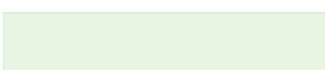
KEY

-  VISIBILITY SPLAY
-  PROPOSED HATCHING
-  EXTEND OF HIGHWAY BOUNDARY TAKEN FROM MAP RECEIVED FROM NORFOLK COUNTY COUNCIL
-  PROPOSED BOLLARDS

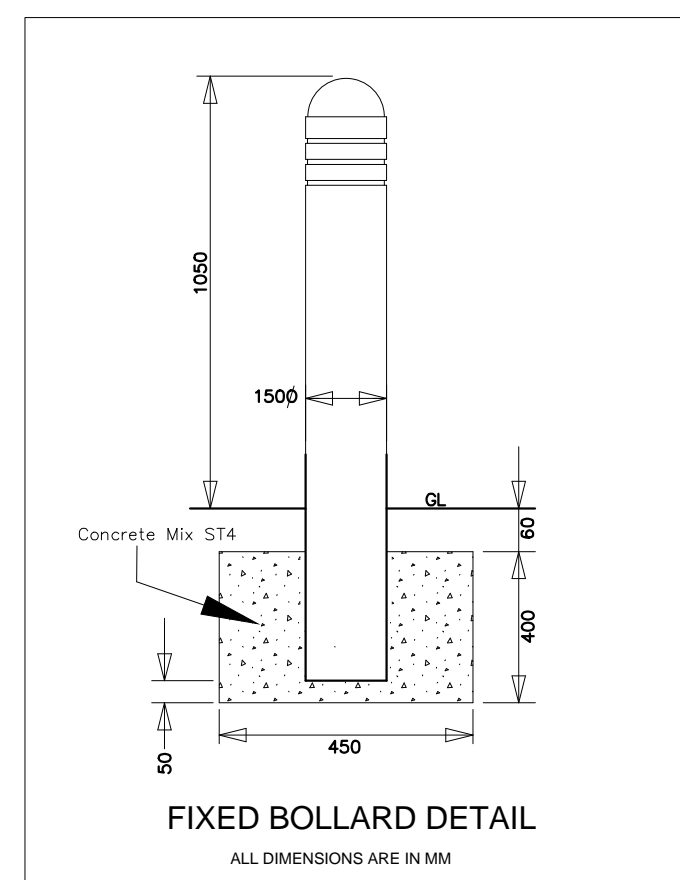
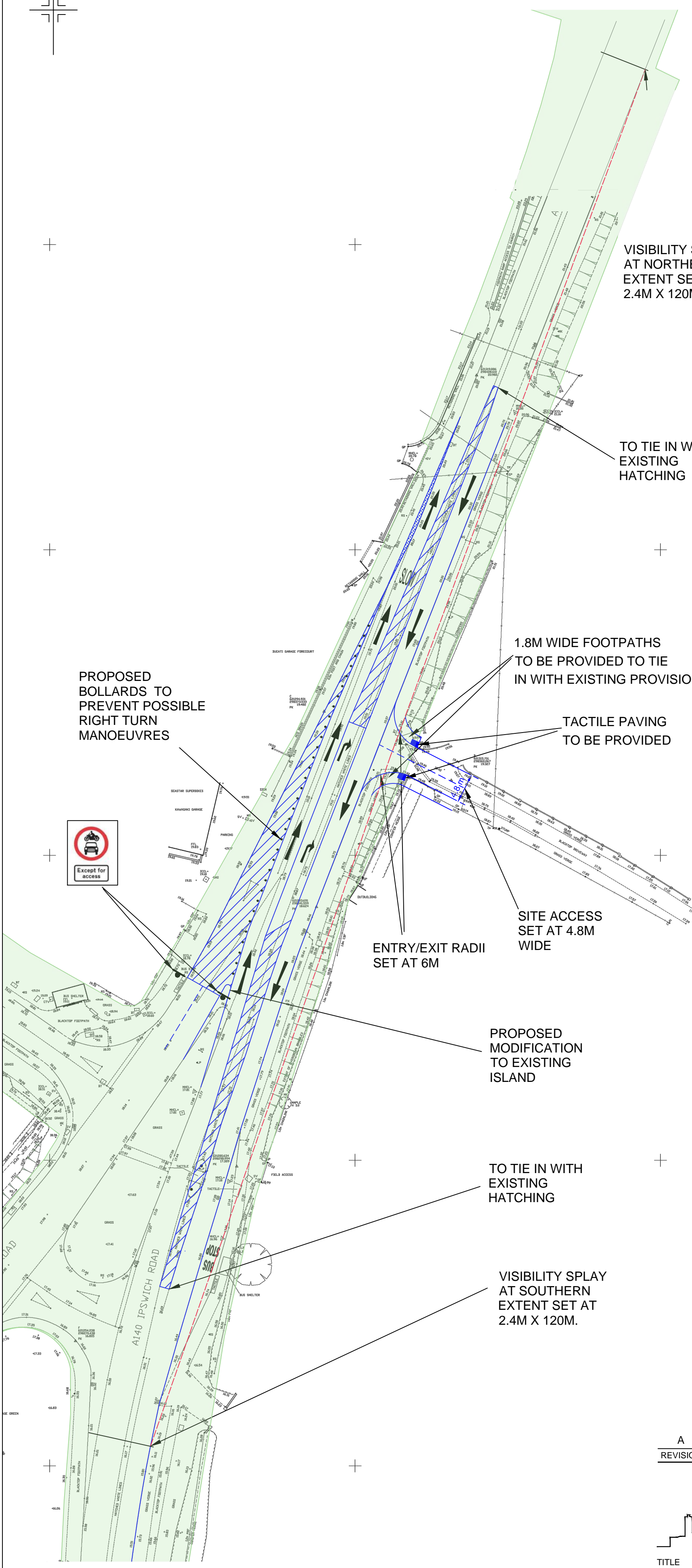

INSERT SCALE 1:20

REVISION	DESCRIPTION	DRAWN	CHECKED	DATE
A	UPDATED TO SUIT SAFETY AUDIT COMMENTS	IZ	GBR	30/08/18

PRELIMINARY INFORMATION TENDER CONSTRUCTION AS BUILT

WOODS HARDWICK
ARCHITECTS, ENGINEERS AND DEVELOPMENT CONSULTANTS

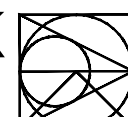

TITLE **LAND EAST OF IPSWICH ROAD
NEWTON FLOTMAN**
DETAILS **SITE ACCESS**

15-17 GOLDINGTON ROAD
BEDFORD, MK40 3NH
T. +44 (0)1234 268862
FORT DUNLOP, FORT PARKWAY
BIRMINGHAM, B24 9FE
UNITED KINGDOM
T. +44 (0)121 6297784
MAIL@WOODSHARDWICK.COM
WWW.WOODSHARDWICK.COM

SCALE: 1:500 @ A2 DATE: 13/06/18 DRAWN: IZ CHK: GBR

17901-IPSW-5-500 A



Appendix D

TRICS Output

TRIP RATE CALCULATION SELECTION PARAMETERS:

Land Use : 03 - RESIDENTIAL
 Category : M - MIXED PRIVATE/AFFORDABLE HOUSING
 TOTAL VEHICLES

Selected regions and areas:

02	SOUTH EAST	
	ES EAST SUSSEX	3 days
	WS WEST SUSSEX	2 days
04	EAST ANGLIA	
	NF NORFOLK	2 days
05	EAST MIDLANDS	
	LE LEICESTERSHIRE	1 days
06	WEST MIDLANDS	
	WM WEST MIDLANDS	1 days
08	NORTH WEST	
	MS MERSEYSIDE	2 days
09	NORTH	
	TW TYNE & WEAR	1 days

This section displays the number of survey days per TRICS® sub-region in the selected set

Primary Filtering selection:

This data displays the chosen trip rate parameter and its selected range. Only sites that fall within the parameter range are included in the trip rate calculation.

Parameter: No of Dwellings
 Actual Range: 16 to 68 (units:)
 Range Selected by User: 9 to 70 (units:)

Parking Spaces Range: All Surveys Included

Parking Spaces per Dwelling Range: All Surveys Included

Bedrooms per Dwelling Range: All Surveys Included

Percentage of dwellings privately owned: All Surveys Included

Public Transport Provision:

Selection by: Include all surveys

Date Range: 01/01/12 to 14/11/19

This data displays the range of survey dates selected. Only surveys that were conducted within this date range are included in the trip rate calculation.

Selected survey days:

Monday	1 days
Tuesday	2 days
Wednesday	3 days
Thursday	2 days
Friday	4 days

This data displays the number of selected surveys by day of the week.

Selected survey types:

Manual count	11 days
Directional ATC Count	1 days

This data displays the number of manual classified surveys and the number of unclassified ATC surveys, the total adding up to the overall number of surveys in the selected set. Manual surveys are undertaken using staff, whilst ATC surveys are undertaken using machines.

Selected Locations:

Edge of Town	8
Neighbourhood Centre (PPS6 Local Centre)	4

This data displays the number of surveys per main location category within the selected set. The main location categories consist of Free Standing, Edge of Town, Suburban Area, Neighbourhood Centre, Edge of Town Centre, Town Centre and Not Known.

Selected Location Sub Categories:

Residential Zone	8
Village	4

This data displays the number of surveys per location sub-category within the selected set. The location sub-categories consist of Commercial Zone, Industrial Zone, Development Zone, Residential Zone, Retail Zone, Built-Up Zone, Village, Out of Town, High Street and No Sub Category.

Secondary Filtering selection:

Use Class:

C3 12 days

This data displays the number of surveys per Use Class classification within the selected set. The Use Classes Order 2005 has been used for this purpose, which can be found within the Library module of TRICS®.

Population within 500m Range:

All Surveys Included

Population within 1 mile:

1,001 to 5,000	7 days
5,001 to 10,000	2 days
20,001 to 25,000	1 days
25,001 to 50,000	2 days

This data displays the number of selected surveys within stated 1-mile radii of population.

Population within 5 miles:

5,001 to 25,000	3 days
25,001 to 50,000	2 days
75,001 to 100,000	2 days
100,001 to 125,000	1 days
125,001 to 250,000	1 days
250,001 to 500,000	3 days

This data displays the number of selected surveys within stated 5-mile radii of population.

Car ownership within 5 miles:

0.6 to 1.0	5 days
1.1 to 1.5	6 days
1.6 to 2.0	1 days

This data displays the number of selected surveys within stated ranges of average cars owned per residential dwelling, within a radius of 5-miles of selected survey sites.

Travel Plan:

Yes	5 days
No	7 days

This data displays the number of surveys within the selected set that were undertaken at sites with Travel Plans in place, and the number of surveys that were undertaken at sites without Travel Plans.

PTAL Rating:

No PTAL Present	12 days
-----------------	---------

This data displays the number of selected surveys with PTAL Ratings.

LIST OF SITES relevant to selection parameters

1	ES-03-M-03 FIELD END MARESFIELD	MIXED HOUSES	EAST SUSSEX
	Edge of Town Residential Zone Total No of Dwellings: 68 <i>Survey date: WEDNESDAY 02/10/13</i>		<i>Survey Type: MANUAL</i>
2	ES-03-M-09 STATION ROAD NORTHAM	DETACHED/SEMI -DETACHED	EAST SUSSEX
	Neighbourhood Centre (PPS6 Local Centre) Village Total No of Dwellings: 16 <i>Survey date: WEDNESDAY 17/05/17</i>		<i>Survey Type: MANUAL</i>
3	ES-03-M-13 NORTH COMMON ROAD WIVELSFIELD GREEN	MIXED HOUSES	EAST SUSSEX
	Neighbourhood Centre (PPS6 Local Centre) Village Total No of Dwellings: 66 <i>Survey date: FRIDAY 22/06/18</i>		<i>Survey Type: MANUAL</i>
4	LE-03-M-01 RYDER ROAD LEICESTER BRAUNSTONE FRITH	SEMI DETACHED	LEICESTERSHIRE
	Edge of Town Residential Zone Total No of Dwellings: 16 <i>Survey date: THURSDAY 27/09/12</i>		<i>Survey Type: MANUAL</i>
5	MS-03-M-02 LOVEL ROAD LIVERPOOL SPEKE	TERRACED	MERSEYSIDE
	Edge of Town Residential Zone Total No of Dwellings: 27 <i>Survey date: FRIDAY 21/06/13</i>		<i>Survey Type: MANUAL</i>
6	MS-03-M-03 LOVEL ROAD LIVERPOOL SPEKE	SEMI DETACHED/TERRACED	MERSEYSIDE
	Edge of Town Residential Zone Total No of Dwellings: 24 <i>Survey date: FRIDAY 21/06/13</i>		<i>Survey Type: MANUAL</i>
7	NF-03-M-19 PIGOT LANE NEAR NORWICH FRAMINGHAM EARL	MIXED HOUSES	NORFOLK
	Neighbourhood Centre (PPS6 Local Centre) Village Total No of Dwellings: 62 <i>Survey date: WEDNESDAY 19/09/18</i>		<i>Survey Type: MANUAL</i>
8	NF-03-M-21 MILL LANE NEAR NORWICH HORSFORD	MIXED HOUSES	NORFOLK
	Neighbourhood Centre (PPS6 Local Centre) Village Total No of Dwellings: 57 <i>Survey date: TUESDAY 11/10/16</i>		<i>Survey Type: DIRECTIONAL ATC COUNT</i>
9	TW-03-M-01 WESTLANDS NEWCASTLE CHAPEL HOUSE	DETACHED & BUNGALOWS	TYNE & WEAR
	Edge of Town Residential Zone Total No of Dwellings: 27 <i>Survey date: FRIDAY 13/11/15</i>		<i>Survey Type: MANUAL</i>

LIST OF SITES relevant to selection parameters (Cont.)

10	WM-03-M-01	SEMI DETACHED	WEST MIDLANDS
	MEADOWSWEET AVENUE		
	BIRMINGHAM		
	KINGS NORTON		
	Edge of Town		
	Residential Zone		
	Total No of Dwellings:	56	
	Survey date: MONDAY	09/11/15	Survey Type: MANUAL
11	WS-03-M-06	SEMI DETACHED/DETACHED	WEST SUSSEX
	SOUTHFIELDS CLOSE		
	CHICHESTER		
	Edge of Town		
	Residential Zone		
	Total No of Dwellings:	67	
	Survey date: TUESDAY	27/01/15	Survey Type: MANUAL
12	WS-03-M-21	MIXED HOUSES	WEST SUSSEX
	CLAPPERS LANE		
	BRACKLESHAM BAY		
	Edge of Town		
	Residential Zone		
	Total No of Dwellings:	57	
	Survey date: THURSDAY	14/11/19	Survey Type: MANUAL

This section provides a list of all survey sites and days in the selected set. For each individual survey site, it displays a unique site reference code and site address, the selected trip rate calculation parameter and its value, the day of the week and date of each survey, and whether the survey was a manual classified count or an ATC count.

MANUALLY DESELECTED SITES

Site Ref	Reason for Deselection
CA-03-M-01	no flats
NF-03-M-04	no flats
WY-03-M-01	no flats

TRIP RATE for Land Use 03 - RESIDENTIAL/M - MIXED PRIVATE/AFFORDABLE HOUSING

TOTAL VEHICLES

Calculation factor: 1 DWELLS

BOLD print indicates peak (busiest) period

Time Range	ARRIVALS			DEPARTURES			TOTALS		
	No. Days	Ave. DWELLS	Trip Rate	No. Days	Ave. DWELLS	Trip Rate	No. Days	Ave. DWELLS	Trip Rate
00:00 - 01:00									
01:00 - 02:00									
02:00 - 03:00									
03:00 - 04:00									
04:00 - 05:00									
05:00 - 06:00									
06:00 - 07:00									
07:00 - 08:00	12	45	0.098	12	45	0.291	12	45	0.389
08:00 - 09:00	12	45	0.155	12	45	0.407	12	45	0.562
09:00 - 10:00	12	45	0.175	12	45	0.208	12	45	0.383
10:00 - 11:00	12	45	0.155	12	45	0.140	12	45	0.295
11:00 - 12:00	12	45	0.203	12	45	0.214	12	45	0.417
12:00 - 13:00	12	45	0.177	12	45	0.164	12	45	0.341
13:00 - 14:00	12	45	0.160	12	45	0.168	12	45	0.328
14:00 - 15:00	12	45	0.177	12	45	0.199	12	45	0.376
15:00 - 16:00	12	45	0.265	12	45	0.214	12	45	0.479
16:00 - 17:00	12	45	0.289	12	45	0.186	12	45	0.475
17:00 - 18:00	12	45	0.359	12	45	0.223	12	45	0.582
18:00 - 19:00	12	45	0.326	12	45	0.197	12	45	0.523
19:00 - 20:00									
20:00 - 21:00									
21:00 - 22:00									
22:00 - 23:00									
23:00 - 24:00									
Total Rates:			2.539			2.611			5.150

This section displays the trip rate results based on the selected set of surveys and the selected count type (shown just above the table). It is split by three main columns, representing arrivals trips, departures trips, and total trips (arrivals plus departures). Within each of these main columns are three sub-columns. These display the number of survey days where count data is included (per time period), the average value of the selected trip rate calculation parameter (per time period), and the trip rate result (per time period). Total trip rates (the sum of the column) are also displayed at the foot of the table.

To obtain a trip rate, the average (mean) trip rate parameter value (TRP) is first calculated for all selected survey days that have count data available for the stated time period. The average (mean) number of arrivals, departures or totals (whichever applies) is also calculated (COUNT) for all selected survey days that have count data available for the stated time period. Then, the average count is divided by the average trip rate parameter value, and multiplied by the stated calculation factor (shown just above the table and abbreviated here as FACT). So, the method is: $COUNT/TRP*FACT$. Trip rates are then rounded to 3 decimal places.

The survey data, graphs and all associated supporting information, contained within the TRICS Database are published by TRICS Consortium Limited ("the Company") and the Company claims copyright and database rights in this published work. The Company authorises those who possess a current TRICS licence to access the TRICS Database and copy the data contained within the TRICS Database for the licence holders' use only. Any resulting copy must retain all copyrights and other proprietary notices, and any disclaimer contained thereon.

The Company accepts no responsibility for loss which may arise from reliance on data contained in the TRICS Database. [No warranty of any kind, express or implied, is made as to the data contained in the TRICS Database.]

Parameter summary

Trip rate parameter range selected: 16 - 68 (units:)
Survey date range: 01/01/12 - 14/11/19
Number of weekdays (Monday-Friday): 12
Number of Saturdays: 0
Number of Sundays: 0
Surveys automatically removed from selection: 1
Surveys manually removed from selection: 3

This section displays a quick summary of some of the data filtering selections made by the TRICS® user. The trip rate calculation parameter range of all selected surveys is displayed first, followed by the range of minimum and maximum survey dates selected by the user. Then, the total number of selected weekdays and weekend days in the selected set of surveys are shown. Finally, the number of survey days that have been manually removed from the selected set outside of the standard filtering procedure are displayed.

Appendix E

Junctions 9 Output

Junctions 9
PICADY 9 - Priority Intersection Module
Version: 9.5.0.6896 © Copyright TRL Limited, 2018
For sales and distribution information, program advice and maintenance, contact TRL: +44 (0)1344 379777 software@trl.co.uk www.trlsoftware.co.uk
The users of this computer program for the solution of an engineering problem are in no way relieved of their responsibility for the correctness of the solution

Filename: Ipswich Road - Site Access.j9
 Path: F:\Engineer\17901\09-Transportation\03-Traffic Models\02-Junctions
 Report generation date: 12/11/2020 13:49:28

»Do Something 2026, AM
 »Do Something 2026, PM

Summary of junction performance

	AM				PM			
	Queue (PCU)	Delay (s)	RFC	LOS	Queue (PCU)	Delay (s)	RFC	LOS
Do Something 2026								
Stream B-C	0.0	6.29	0.02	A	0.0	6.55	0.01	A
Stream B-A	0.0	8.28	0.00	A	0.0	8.84	0.00	A
Stream C-AB	0.0	5.77	0.00	A	0.0	6.12	0.01	A

Values shown are the highest values encountered over all time segments. Delay is the maximum value of average delay per arriving vehicle.

File summary

File Description

Title	
Location	
Site number	
Date	12/11/2020
Version	
Status	(new file)
Identifier	
Client	
Jobnumber	
Enumerator	WHI.planning
Description	

Units

Distance units	Speed units	Traffic units input	Traffic units results	Flow units	Average delay units	Total delay units	Rate of delay units
m	kph	PCU	PCU	perHour	s	-Min	perMin

Analysis Options

Vehicle length (m)	Calculate Queue Percentiles	Calculate detailed queueing delay	Calculate residual capacity	RFC Threshold	Average Delay threshold (s)	Queue threshold (PCU)
5.75				0.85	36.00	20.00

Demand Set Summary

ID	Scenario name	Time Period name	Traffic profile type	Start time (HH:mm)	Finish time (HH:mm)	Time period length (min)	Time segment length (min)	Run automatically
D5	Do Something 2026	AM	DIRECT	08:00	09:00	60	15	✓
D6	Do Something 2026	PM	DIRECT	17:00	18:00	60	15	✓

Analysis Set Details

ID	Include in report	Network flow scaling factor (%)	Network capacity scaling factor (%)
A1	✓	100.000	100.000

Do Something 2026, AM

Data Errors and Warnings

No errors or warnings

Junction Network

Junctions

Junction	Name	Junction type	Major road direction	Use circulating lanes	Junction Delay (s)	Junction LOS
1	Ipswich Road, Site Access	T-Junction	Two-way		0.16	A

Junction Network Options

Driving side	Lighting
Left	Normal/unknown

Arms

Arms

Arm	Name	Description	Arm type
A	Ipswich Road (N)		Major
B	Site Access		Minor
C	Ipswich Road (S)		Major

Major Arm Geometry

Arm	Width of carriageway (m)	Has kerbed central reserve	Has right turn bay	Width for right turn (m)	Visibility for right turn (m)	Blocks?	Blocking queue (PCU)
C	6.00		✓	3.00	90.0	✓	5.00

Geometries for Arm C are measured opposite Arm B. Geometries for Arm A (if relevant) are measured opposite Arm D.

Minor Arm Geometry

Arm	Minor arm type	Width at give-way (m)	Width at 5m (m)	Width at 10m (m)	Width at 15m (m)	Width at 20m (m)	Estimate flare length	Flare length (PCU)	Visibility to left (m)	Visibility to right (m)
B	One lane plus flare	8.41	2.62	2.40	2.40	2.40		1.00	65	15

Slope / Intercept / Capacity

Priority Intersection Slopes and Intercepts

Junction	Stream	Intercept (PCU/hr)	Slope for A-B	Slope for A-C	Slope for C-A	Slope for C-B
1	B-A	527	0.096	0.243	0.153	0.346
1	B-C	631	0.097	0.245	-	-
1	C-B	681	0.264	0.264	-	-

The slopes and intercepts shown above do NOT include any corrections or adjustments.

Streams may be combined, in which case capacity will be adjusted.

Values are shown for the first time segment only; they may differ for subsequent time segments.

Traffic Demand

Demand Set Details

ID	Scenario name	Time Period name	Traffic profile type	Start time (HH:mm)	Finish time (HH:mm)	Time period length (min)	Time segment length (min)	Run automatically
D5	Do Something 2026	AM	DIRECT	08:00	09:00	60	15	✓

Vehicle mix varies over turn	Vehicle mix varies over entry	Vehicle mix source	PCU Factor for a HV (PCU)	O-D data varies over time
✓	✓	HV Percentages	2.00	✓

Demand overview (Traffic)

Arm	Linked arm	Profile type	Use O-D data	Scaling Factor (%)
A		DIRECT	✓	100.000
B		DIRECT	✓	100.000
C		DIRECT	✓	100.000

Origin-Destination Data

Demand (PCU/hr)

08:00 - 08:15

		To		
		A	B	C
From	A	0	0.07	204
	B	0.20	0	9
	C	272	3	0

Demand (PCU/hr)

08:15 - 08:30

		To		
		A	B	C
From	A	0	0.07	185
	B	0.20	0	9
	C	265	3	0

Demand (PCU/hr)

08:30 - 08:45

		To		
		A	B	C
From	A	0	0.07	174
	B	0.20	0	9
	C	245	3	0

Demand (PCU/hr)

08:45 - 09:00

		To		
		A	B	C
From	A	0	0.07	134
	B	0.20	0	9
	C	266	3	0

Vehicle Mix

Heavy Vehicle Percentages

		To		
		A	B	C
From	A	0	0	3
	B	0	0	0
	C	3	0	0

Results

Results Summary for whole modelled period

Stream	Max RFC	Max Delay (s)	Max Queue (PCU)	Max LOS	Average Demand (PCU/hr)	Total Junction Arrivals (PCU)
B-C	0.02	6.29	0.0	A	9	9
B-A	0.00	8.28	0.0	A	0.20	0.20
C-AB	0.00	5.77	0.0	A	3	3
C-A					262	262
A-B					0.07	0.07
A-C					174	174

Main Results for each time segment

08:00 - 08:15

Stream	Total Demand (PCU/hr)	Junction Arrivals (PCU)	Capacity (PCU/hr)	RFC	Throughput (PCU/hr)	Start queue (PCU)	End queue (PCU)	Delay (s)	Unsignalised level of service
B-C	9	2	581	0.015	9	0.0	0.0	6.288	A
B-A	0.20	0.05	435	0.000	0.20	0.0	0.0	8.282	A
C-AB	3	0.73	627	0.005	3	0.0	0.0	5.768	A
C-A	272	68			272				
A-B	0.07	0.02			0.07				
A-C	204	51			204				

08:15 - 08:30

Stream	Total Demand (PCU/hr)	Junction Arrivals (PCU)	Capacity (PCU/hr)	RFC	Throughput (PCU/hr)	Start queue (PCU)	End queue (PCU)	Delay (s)	Unsignalised level of service
B-C	9	2	586	0.015	9	0.0	0.0	6.238	A
B-A	0.20	0.05	440	0.000	0.20	0.0	0.0	8.178	A
C-AB	3	0.73	632	0.005	3	0.0	0.0	5.724	A
C-A	265	66			265				
A-B	0.07	0.02			0.07				
A-C	185	46			185				

08:30 - 08:45

Stream	Total Demand (PCU/hr)	Junction Arrivals (PCU)	Capacity (PCU/hr)	RFC	Throughput (PCU/hr)	Start queue (PCU)	End queue (PCU)	Delay (s)	Unsignalised level of service
B-C	9	2	588	0.015	9	0.0	0.0	6.212	A
B-A	0.20	0.05	446	0.000	0.20	0.0	0.0	8.073	A
C-AB	3	0.73	635	0.005	3	0.0	0.0	5.698	A
C-A	245	61			245				
A-B	0.07	0.02			0.07				
A-C	174	44			174				

08:45 - 09:00

Stream	Total Demand (PCU/hr)	Junction Arrivals (PCU)	Capacity (PCU/hr)	RFC	Throughput (PCU/hr)	Start queue (PCU)	End queue (PCU)	Delay (s)	Unsignalised level of service
B-C	9	2	598	0.015	9	0.0	0.0	6.108	A
B-A	0.20	0.05	453	0.000	0.20	0.0	0.0	7.956	A
C-AB	3	0.73	645	0.005	3	0.0	0.0	5.606	A
C-A	266	66			266				
A-B	0.07	0.02			0.07				
A-C	134	33			134				

Do Something 2026, PM

Data Errors and Warnings

No errors or warnings

Junction Network

Junctions

Junction	Name	Junction type	Major road direction	Use circulating lanes	Junction Delay (s)	Junction LOS
1	Ipswich Road, Site Access	T-Junction	Two-way		0.15	A

Junction Network Options

Driving side	Lighting
Left	Normal/unknown

Traffic Demand

Demand Set Details

ID	Scenario name	Time Period name	Traffic profile type	Start time (HH:mm)	Finish time (HH:mm)	Time period length (min)	Time segment length (min)	Run automatically
D6	Do Something 2026	PM	DIRECT	17:00	18:00	60	15	✓

Vehicle mix varies over turn	Vehicle mix varies over entry	Vehicle mix source	PCU Factor for a HV (PCU)	O-D data varies over time
✓	✓	HV Percentages	2.00	✓

Demand overview (Traffic)

Arm	Linked arm	Profile type	Use O-D data	Scaling Factor (%)
A		DIRECT	✓	100.000
B		DIRECT	✓	100.000
C		DIRECT	✓	100.000

Origin-Destination Data

Demand (PCU/hr)

17:00 - 17:15

		To		
		A	B	C
From	A	0	0.19	317
	B	0.10	0	4
	C	260	8	0

Demand (PCU/hr)

17:15 - 17:30

		To		
		A	B	C
From	A	0	0.19	281
	B	0.10	0	4
	C	230	8	0

Demand (PCU/hr)

17:30 - 17:45

		To		
		A	B	C
From	A	0	0.19	301
	B	0.10	0	4
	C	206	8	0

Demand (PCU/hr)

17:45 - 18:00

		To		
		A	B	C
From	A	0	0.19	291
	B	0.10	0	4
	C	200	8	0

Vehicle Mix

Heavy Vehicle Percentages

		To		
		A	B	C
From	A	0	0	2
	B	0	0	0
	C	2	0	0

Results

Results Summary for whole modelled period

Stream	Max RFC	Max Delay (s)	Max Queue (PCU)	Max LOS	Average Demand (PCU/hr)	Total Junction Arrivals (PCU)
B-C	0.01	6.55	0.0	A	4	4
B-A	0.00	8.84	0.0	A	0.10	0.10
C-AB	0.01	6.12	0.0	A	8	8
C-A					224	224
A-B					0.19	0.19
A-C					298	298

Main Results for each time segment

17:00 - 17:15

Stream	Total Demand (PCU/hr)	Junction Arrivals (PCU)	Capacity (PCU/hr)	RFC	Throughput (PCU/hr)	Start queue (PCU)	End queue (PCU)	Delay (s)	Unsignalised level of service
B-C	4	1	553	0.008	4	0.0	0.0	6.553	A
B-A	0.10	0.02	407	0.000	0.09	0.0	0.0	8.840	A
C-AB	8	2	597	0.014	8	0.0	0.0	6.115	A
C-A	260	65			260				
A-B	0.19	0.05			0.19				
A-C	317	79			317				

17:15 - 17:30

Stream	Total Demand (PCU/hr)	Junction Arrivals (PCU)	Capacity (PCU/hr)	RFC	Throughput (PCU/hr)	Start queue (PCU)	End queue (PCU)	Delay (s)	Unsignalised level of service
B-C	4	1	562	0.007	4	0.0	0.0	6.452	A
B-A	0.10	0.02	420	0.000	0.10	0.0	0.0	8.562	A
C-AB	8	2	606	0.014	8	0.0	0.0	6.021	A
C-A	230	58			230				
A-B	0.19	0.05			0.19				
A-C	281	70			281				

17:30 - 17:45

Stream	Total Demand (PCU/hr)	Junction Arrivals (PCU)	Capacity (PCU/hr)	RFC	Throughput (PCU/hr)	Start queue (PCU)	End queue (PCU)	Delay (s)	Unsignalised level of service
B-C	4	1	557	0.007	4	0.0	0.0	6.505	A
B-A	0.10	0.02	419	0.000	0.10	0.0	0.0	8.585	A
C-AB	8	2	601	0.014	8	0.0	0.0	6.071	A
C-A	206	52			206				
A-B	0.19	0.05			0.19				
A-C	301	75			301				

17:45 - 18:00

Stream	Total Demand (PCU/hr)	Junction Arrivals (PCU)	Capacity (PCU/hr)	RFC	Throughput (PCU/hr)	Start queue (PCU)	End queue (PCU)	Delay (s)	Unsignalised level of service
B-C	4	1	560	0.007	4	0.0	0.0	6.480	A
B-A	0.10	0.02	423	0.000	0.10	0.0	0.0	8.518	A
C-AB	8	2	604	0.014	8	0.0	0.0	6.047	A
C-A	200	50			200				
A-B	0.19	0.05			0.19				
A-C	291	73			291				

Appendix D

Correspondence between Woods Hardwick
and the Highway Authority

Inez Ziecina

From: George Beevor-Reid
Sent: 23 July 2021 15:41
To: Inez Ziecina
Subject: FW: Ipswich Road, Newton Flotman (17901): Revised Highway Proposals.

Regards,
For & on behalf of Woods Hardwick Infrastructure LLP

George Beevor-Reid BA (Hons) MCIHT
Associate Director

M: 07585 790089



BEDFORD OFFICE
15-17 Goldington Road
Bedford
MK40 3NH

T: 01234 268862
W: woodshardwick.com

Please consider the environment before printing this email

Disclaimer: The information contained within this Email, including any attachments, is intended for the sole use of the person to whom the Email is addressed and may contain confidential and/or privileged information. If you received the information in error please contact Woods Hardwick 01234 268862 and delete the email including attachments from your computer. Woods Hardwick accept no legal liability for the content of the message. Any opinions or views presented are solely the responsibility of the author and do not necessarily represent those of Woods Hardwick. Woods Hardwick may monitor the content of emails sent and received via its network for the purposes of ensuring compliance with its policies and procedures. Although we have taken reasonable steps to ensure that this email and attachments are free from any virus, we advise that in keeping with good computing practice the recipient should ensure they are actually virus free. Protection of our Copyright and Intellectual Property Rights.

1. All design rights and copyright in all technical information drawings models bills of quantities specifications schedules details plans calculations or other materials provided or to be provided by the Us in respect of the Project and all amendments and additions thereto (whether in existence or yet to be made) and any works designs or inventions by Us incorporated or referred to in the Project ("the Documents") shall remain vested in Us. 2(a). Upon payment of Our Fee in full, We grant to You a non-exclusive royalty-free licence to use and reproduce the Documents for all purposes relating to the Project only. The licence extends to use of the Documents for the extension of the Project, but such use shall not include a licence to reproduce the designs contained in the Documents for any extension of the Project or any other project. 2(b). The Documents will be provided in non-editable format only. If You wish to edit or modify the Documents or wish your contractors, agents or consultants to edit or modify the Documents then You must ask for Our agreement in writing first. We shall be entitled to payment of an Additional Fee which must be paid in full by You before permission is granted. 2(c) Should We agree under clause 2(b) to provide editable Documents to You and/or your contractors, agents or consultants; they and You are only permitted to modify the Documents including the intellectual property contained therein for the purposes of the Project and no other project or purposes; to use on other projects or for other purposes will be an infringement of our intellectual property rights. 3. We shall not be liable for any use of the material for any purpose other than that for which they were originally prepared. 4. Where Our reports include third party material, such as photographs or plans, all copyright issues and payments will be Your responsibility.

Woods Hardwick Ltd. Registered in England No. 2133642 Registered Office: 1 RUSHMILLS, NORTHAMPTON, NN4 7YB
VAT Number:479305421GB

From: Willeard, Andrew <andrew.willeard@norfolk.gov.uk>
Sent: 13 May 2021 12:54
To: George Beevor-Reid <G.Beevor-Reid@WoodsHardwick.com>
Cc: Paul Woods <p.woods@WoodsHardwick.com>; Inez Ziecina <i.ziecina@WoodsHardwick.com>
Subject: RE: Ipswich Road, Newton Flotman (17901): Revised Highway Proposals.

George

I am not in discussion with District on this site. If your planning team wish to make the District aware of my comments, I have no objection.

Andrew Willeard, Engineer (Estate & Major Development)
Community and Environmental Services

Tel: 01603 228948
County Hall, Martineau Lane, Norwich NR1 2SG



From: George Beevor-Reid <G.Beevor-Reid@WoodsHardwick.com>
Sent: 13 May 2021 12:47
To: Willeard, Andrew <andrew.willeard@norfolk.gov.uk>
Cc: Paul Woods <p.woods@WoodsHardwick.com>; Inez Ziecina <i.ziecina@WoodsHardwick.com>
Subject: RE: Ipswich Road, Newton Flotman (17901): Revised Highway Proposals.

WARNING: External email, think before you click!.

Good Afternoon Andrew,

Many thanks for responding to our latest submission and for taking the time to discuss with your colleagues.

We note your comments and would review fully and respond accordingly to the details noted at such time as an application is progressed.

In the meantime my planning colleagues will appraise the District Council of our latest discussions to assist the site assessment process. I am not sure if you were also intending to report back to the District regarding the below, but if you are able to that would be appreciated.

Thank you again and we will no doubt discuss further in due course.

Regards,
For & on behalf of Woods Hardwick Infrastructure LLP

George Beevor-Reid BA (Hons) MCIHT
Associate Director

M: 07585 790089



BEDFORD OFFICE
15-17 Goldington Road
Bedford
MK40 3NH

T: 01234 268862
W: woodshardwick.com

Please consider the environment before printing this email

Disclaimer: The information contained within this Email, including any attachments, is intended for the sole use of the person to whom the Email is addressed and may contain confidential and/or privileged information. If you received the information in error please contact Woods Hardwick 01234 268862 and delete the email including attachments from your computer. Woods Hardwick accept no legal liability for the content of the message. Any opinions or views presented are solely the responsibility of the author and do not necessarily represent those of Woods Hardwick. Woods Hardwick may monitor the content of emails sent and received via its network for the purposes of ensuring compliance with its policies and procedures. Although we have taken reasonable steps to ensure that this email and attachments are free from any virus, we advise that in keeping with good computing practice the recipient should ensure they are actually virus free. Protection of our Copyright and Intellectual Property Rights.

1. All design rights and copyright in all technical information drawings models bills of quantities specifications schedules details plans calculations or other materials provided or to be provided by the Us in respect of the Project and all amendments and additions thereto (whether in existence or yet to be made) and any works designs or inventions by Us incorporated or referred to in the Project ("the Documents") shall remain vested in Us. 2(a). Upon payment of Our Fee in full, We grant to You a non-exclusive royalty-free licence to use and reproduce the Documents for all purposes relating to the Project only. The licence extends to use of the Documents for the extension of the Project, but such use shall not include a licence to reproduce the designs contained in the Documents for any extension of the

Project or any other project. 2(b). The Documents will be provided in non-editable format only. If You wish to edit or modify the Documents or wish your contractors, agents or consultants to edit or modify the Documents then You must ask for Our agreement in writing first. We shall be entitled to payment of an Additional Fee which must be paid in full by You before permission is granted. 2(c) Should We agree under clause 2(b) to provide editable Documents to You and/or your contractors, agents or consultants; they and You are only permitted to modify the Documents including the intellectual property contained therein for the purposes of the Project and no other project or purposes; to use on other projects or for other purposes will be an infringement of our intellectual property rights. 3. We shall not be liable for any use of the material for any purpose other than that for which they were originally prepared. 4. Where Our reports include third party material, such as photographs or plans, all copyright issues and payments will be Your responsibility.

Woods Hardwick Ltd. Registered in England No. 2133642 Registered Office: 1 RUSHMILLS, NORTHAMPTON, NN4 7YB
VAT Number:479305421GB

From: Willeard, Andrew <andrew.willeard@norfolk.gov.uk>
Sent: 11 May 2021 13:19
To: George Beevor-Reid <G.Beevor-Reid@WoodsHardwick.com>
Cc: Paul Woods <p.woods@WoodsHardwick.com>; Inez Ziecina <i.ziecina@WoodsHardwick.com>
Subject: RE: Ipswich Road, Newton Flotman (17901): Revised Highway Proposals.

George

Thank you for sending me drawing 17901-IPSW-5-500 rev B showing back to back right turn lanes and a staggered ped crossing. This proposal was discussed at a recent development team meeting and considered to be acceptable in principle, subject to a stage 1 safety audit and future detailed design.

However, the proposed layout does adequately provide for maintaining an acceptable access to the Theatre School and garage site by all appropriate vehicles. This would appear to be a particular issue for the garage site, which currently has the right to access Ipswich Road across the majority of its frontage. Any changes to their access arrangements are therefore likely to need their agreement, in addition to approval from the County Council.

Should you wish to proceed with these proposals in mitigation of a future planning application, I would expect the above access issue to be addressed, a stage 1 safety audit undertaken and analysis of the junctions operation demonstrating that the changes do not have a detrimental impact on the function of A140. It will also need to be tracked by all appropriate service / delivery vehicles, to demonstrate it can be safely navigated.

If you have any further queries regarding the above do not hesitate to contact me.

Andrew Willeard, Engineer (Estate & Major Development)

Community and Environmental Services

Tel: 01603 228948

County Hall, Martineau Lane, Norwich NR1 2SG

 **Norfolk County Council**   

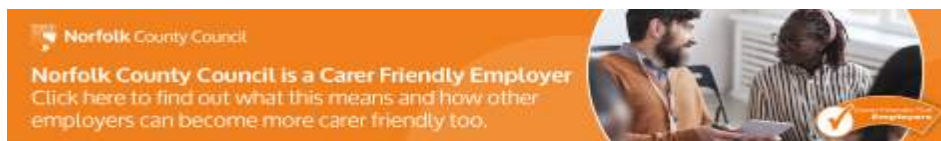

From: George Beevor-Reid <G.Beevor-Reid@WoodsHardwick.com>
Sent: 09 April 2021 16:45
To: Willeard, Andrew <andrew.willeard@norfolk.gov.uk>
Cc: Paul Woods <p.woods@WoodsHardwick.com>; Inez Ziecina <i.ziecina@WoodsHardwick.com>
Subject: RE: Ipswich Road, Newton Flotman (17901): Revised Highway Proposals.

WARNING: External email, think before you click!.

Dear Andrew,

I hope you are well.

You will recall that we discussed the above scheme and specifically the access requirements earlier in the year.

Since we spoke we have reviewed the Technical Note that you kindly provided in relation to potential improvement works to the south. We have also reviewed the latest available Transportation documentation in relation to the large development at Long Stratton further to the south.

From our review of the modelling contained within the two documents it is evident that the Flordon Road junction is currently considered to operate within capacity and it is the development at Long Stratton which pushes it over capacity and necessitates mitigation.

From the RFC values presented in the documents it is extremely unlikely that our proposed development of c30 dwellings would push the junction over capacity, though if considered necessary we would be prepared to undertake a model of the junction ourselves to confirm this point.

Notwithstanding the above, you advised in your email below that if we were to present a scheme that includes back to back right turn lanes, 4.5 x 120m visibility splays and an enhanced pedestrian crossing facility you would be willing to consider the proposals further.

We have therefore prepared the attached drawing indicating how this could be achieved and we would be grateful if you could review and provide your thoughts.

Many thanks and happy to discuss over the phone if easier.

Regards,
For & on behalf of Woods Hardwick Infrastructure LLP

George Beevor-Reid BA (Hons) MCIHT
Associate Director

M: 07585 790089



BEDFORD OFFICE
15-17 Goldington Road
Bedford
MK40 3NH

T: 01234 268862
W: woodshardwick.com

Please consider the environment before printing this email

Disclaimer: The information contained within this Email, including any attachments, is intended for the sole use of the person to whom the Email is addressed and may contain confidential and/or privileged information. If you received the information in error please contact Woods Hardwick 01234 268862 and delete the email including attachments from your computer. Woods Hardwick accept no legal liability for the content of the message. Any opinions or views presented are solely the responsibility of the author and do not necessarily represent those of Woods Hardwick. Woods Hardwick may monitor the content of emails sent and received via its network for the purposes of ensuring compliance with its policies and procedures. Although we have taken reasonable steps to ensure that this email and attachments are free from any virus, we advise that in keeping with good computing practice the recipient should ensure they are actually virus free. Protection of our Copyright and Intellectual Property Rights.

1. All design rights and copyright in all technical information drawings models bills of quantities specifications schedules details plans calculations or other materials provided or to be provided by the Us in respect of the Project and all amendments and additions thereto (whether in existence or yet to be made) and any works designs or inventions by Us incorporated or referred to in the Project ("the Documents") shall remain vested in Us. 2(a). Upon payment of Our Fee in full, We grant to You a non-exclusive royalty-free licence to use and reproduce the Documents for all purposes relating to the Project only. The licence extends to use of the Documents for the extension of the Project, but such use shall not include a licence to reproduce the designs contained in the Documents for any extension of the Project or any other project. 2(b). The Documents will be provided in non-editable format only. If You wish to edit or modify the Documents or wish your contractors, agents or consultants to edit or modify the Documents then You must ask for Our agreement in writing first. We shall be entitled to payment of an Additional Fee which must be paid in full by You before permission is granted. 2(c) Should We agree under clause 2(b) to provide editable Documents to You and/or your contractors, agents or consultants; they and You are only permitted to modify the Documents including the intellectual property contained therein for the purposes of the Project and no other project or purposes; to use on other projects or for other purposes will be an infringement of our intellectual property rights. 3. We shall not be liable for any use of the material for any purpose other than that for which they were originally prepared. 4. Where Our reports include third party material, such as photographs or plans, all copyright issues and payments will be Your responsibility.

Woods Hardwick Ltd. Registered in England No. 2133642 Registered Office: 1 RUSHMILLS, NORTHAMPTON, NN4 7YB
VAT Number:479305421GB

From: Willeard, Andrew <andrew.willeard@norfolk.gov.uk>

Sent: 22 January 2021 11:32

To: George Beevor-Reid <G.Beevor-Reid@WoodsHardwick.com>

Cc: Paul Woods <p.woods@WoodsHardwick.com>

Subject: RE: Ipswich Road, Newton Flotman (17901): Revised Highway Proposals.

George

Apologies for the delay in providing a response to your email below.

As you recall, when I was last consulted on this proposal we commented that our objection was in relation to a matter of principle and that any new junction onto the A140 would be resisted. However, I note your new Technical Note dated 27/11/2020 seeks to address those concerns, by the introduction of a right turn lane.

Having considered this proposal at a recent Development Team meeting, the conclusion was that our objections to the principle of a new junction should remain, in addition to our concerns regarding the significant increase in pedestrians needing to cross the A140 to reach local services and the rest of the village. I was also made aware of the attached report produced in 2017 for the County Council in relation to potential options for providing a junction improvement in the centre of Newton Flotman and to rationalise the number of existing points of access to the A140.

You will note from this report that a right turn lane option was considered, but it was found to result in significant delays from Flordon Road (an issue that may also be likely at any new development access) and would also make access by HGVs much more difficult. It also highlighted the high number of serious and fatal accidents that have occurred at this junction. Notwithstanding the concerns with the existing layout, none of these options are currently being pursued.

Therefore adding another junction, without addressing the existing issues at this location would continue to be resisted by the County Council.

Notwithstanding the above, should a scheme be put forward that provides back to back right turn lanes with Flordon Road, addresses the issues with HGV access, etc identified in our report and provides 4.5 x 120m visibility splays, I would be willing to raise the matter again with our Development Team.

As you will be aware any scheme will also need to improve pedestrian crossing facilities and whilst a controlled crossing would not be appropriate at this location, an improvement on the existing refuge should be provided. This should include provision of a larger waiting area incorporating a staggered crossing similar to the photo below.



If you have any further queries do not hesitate to contact me.

Andrew Willeard, Engineer (Estate & Major Development)

Community and Environmental Services

Tel: 01603 228948

County Hall, Martineau Lane, Norwich NR1 2SG

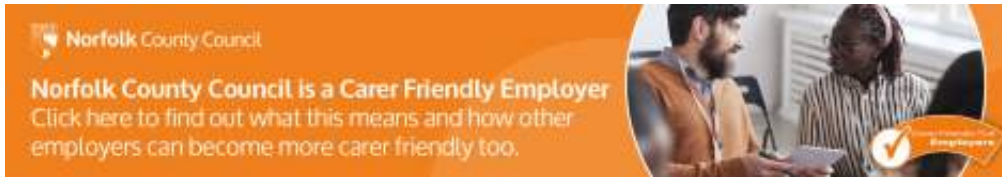

From: George Beevor-Reid <G.Beevor-Reid@WoodsHardwick.com>
Sent: 15 December 2020 10:20
To: Willeard, Andrew <andrew.willeard@norfolk.gov.uk>
Cc: Paul Woods <p.woods@WoodsHardwick.com>
Subject: RE: Ipswich Road, Newton Flotman (17901): Revised Highway Proposals.

WARNING: External email, think before you click!.

Good Morning Andrew,

I just wondered if you could advise when you are likely to be in a position to advise on the below.

If any further information from me would assist please let me know.

Many thanks.

Regards,
For & on behalf of Woods Hardwick Infrastructure LLP

George Beevor-Reid BA (Hons) MCIHT
Associate Director

M: 07585 790089



BEDFORD OFFICE
15-17 Goldington Road
Bedford
MK40 3NH

T: 01234 268862
W: woodshardwick.com

Please consider the environment before printing this email

Disclaimer: The information contained within this Email, including any attachments, is intended for the sole use of the person to whom the Email is addressed and may contain confidential and/or privileged information. If you received the information in error please contact Woods Hardwick 01234 268862 and delete the email including attachments from your computer. Woods Hardwick accept no legal liability for the content of the message. Any opinions or views presented are solely the responsibility of the author and do not necessarily represent those of Woods Hardwick. Woods Hardwick may monitor the content of emails sent and received via its network for the purposes of ensuring compliance with its policies and procedures. Although we have taken reasonable steps to ensure that this email and attachments are free from any virus, we advise that in keeping with good computing practice the recipient should ensure they are actually virus free. Protection of our Copyright and Intellectual Property Rights.

1. All design rights and copyright in all technical information drawings models bills of quantities specifications schedules details plans calculations or other materials provided or to be provided by the Us in respect of the Project and all amendments and additions thereto (whether in existence or yet to be made) and any works designs or inventions by Us incorporated or referred to in the Project ("the Documents") shall remain vested in Us. 2(a). Upon payment of Our Fee in full, We grant to You a non-exclusive royalty-free licence to use and reproduce the Documents for all purposes relating to the Project only. The licence extends to use of the Documents for the extension of the Project, but such use shall not include a licence to reproduce the designs contained in the Documents for any extension of the Project or any other project. 2(b). The Documents will be provided in non-editable format only. If You wish to edit or modify the Documents or wish your contractors, agents or consultants to edit or modify the Documents then You must ask for Our agreement in writing first. We shall be entitled to payment of an Additional Fee which must be paid in full by You before permission is granted. 2(c) Should We agree under clause 2(b) to provide editable Documents to You and/or your contractors, agents or consultants; they and You are only permitted to modify the Documents including the intellectual property contained therein for the purposes of the Project and no other project or purposes; to use on other projects or for other purposes will be an infringement of our intellectual property rights. 3. We shall not be liable for any use of the material for any purpose other than that for which they were originally prepared. 4. Where Our reports include third party material, such as photographs or plans, all copyright issues and payments will be Your responsibility.

From: George Beevor-Reid
Sent: 01 December 2020 15:40
To: 'andrew.willeard@norfolk.gov.uk' <andrew.willeard@norfolk.gov.uk>
Cc: Paul Woods <p.woods@WoodsHardwick.com>
Subject: Ipswich Road, Newton Flotman (17901): Revised Highway Proposals.

Good Afternoon Andrew,

I hope you are well.

You may recall that a couple of years ago we discussed proposals to develop my clients land at Newton Flotman shown on the attached Location Plan for up to 33 dwellings.

Since the original submission we have revisited the proposals with the aim of addressing your previous concerns as summarised in the attached Technical Note.

It would be very much appreciated if you could review the attached and let us know your thoughts.

I would of course be pleased to discuss any of the above or attached.

Many thanks.

--

To see our email disclaimer click here <http://www.norfolk.gov.uk/emaildisclaimer>

--

To see our email disclaimer click here <http://www.norfolk.gov.uk/emaildisclaimer>

--

To see our email disclaimer click here <http://www.norfolk.gov.uk/emaildisclaimer>

Appendix E

Site Access drawing

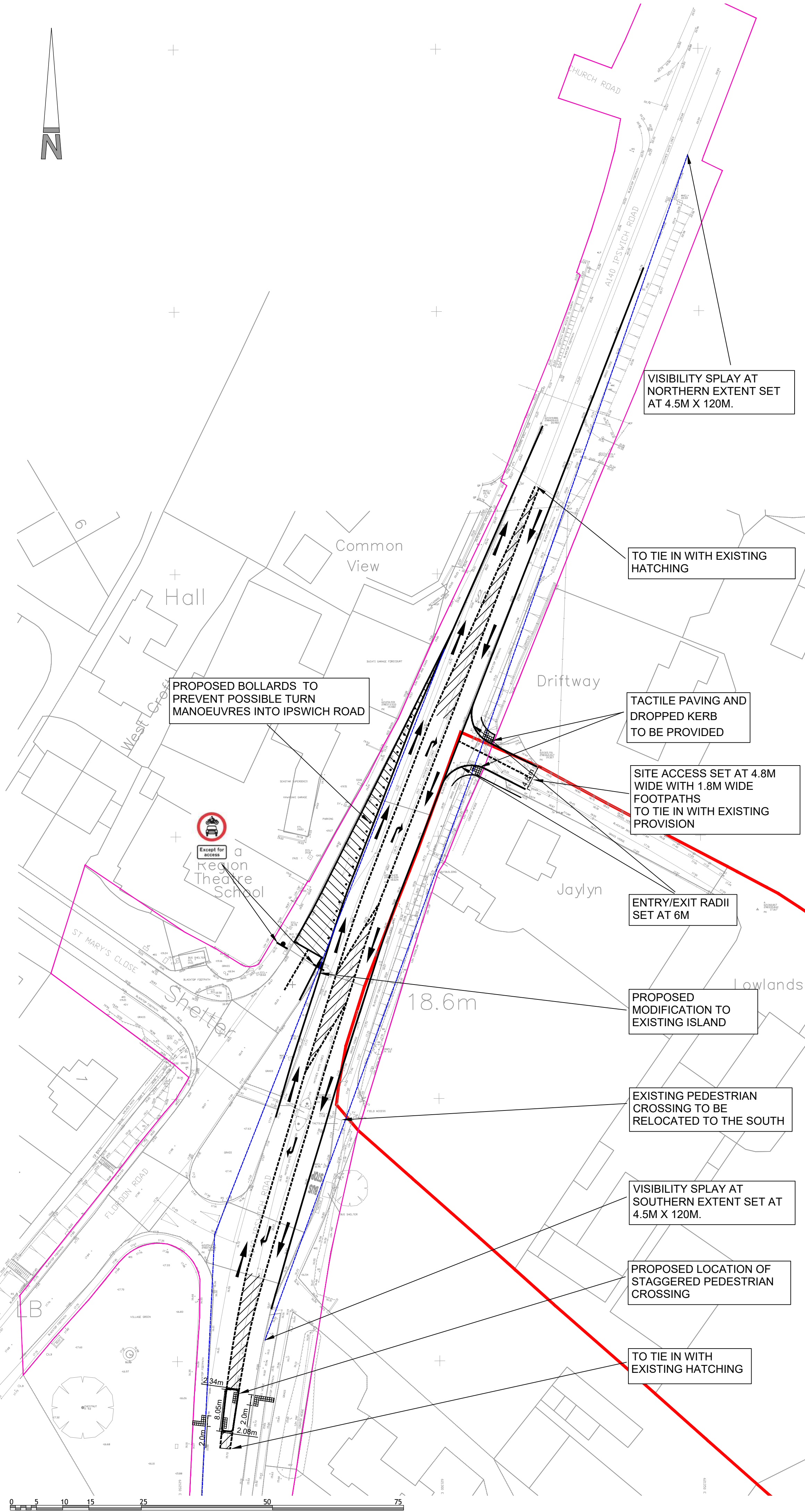
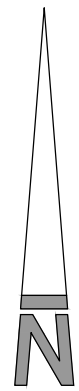

NOTES

- Contractors must check all dimensions on site. Only figured dimensions are to be worked from. Discrepancies must be reported to the Architect or Engineer before proceeding. © This drawing is copyright.
- Reproduced from OS Sitemap © by permission of Ordnance Survey on behalf of The Controller of Her Majesty's Stationary Office. © Crown copyright 2008. All rights reserved. Licence number 100007126.

KEY

- Visibility Splays 4.5m x 120m
- Proposed Channel
- Proposed Footway
- Proposed Hatching
- Extend of highway boundary taken from map received from Norfolk County Council
- Proposed bollards

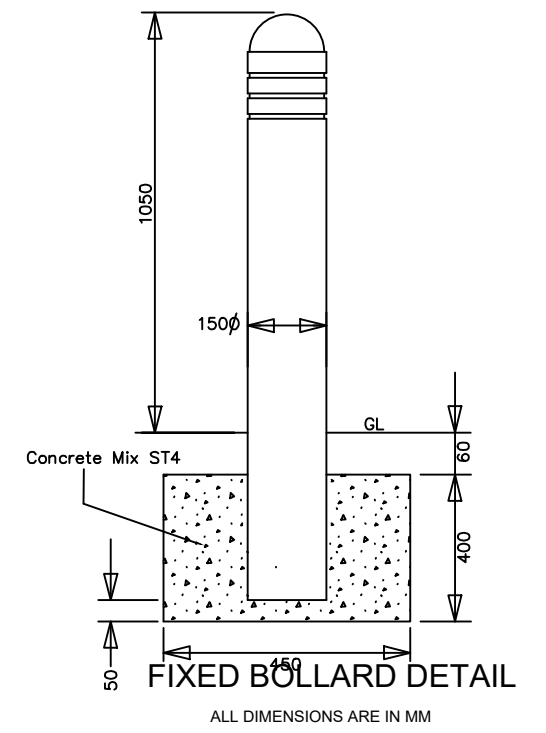

B	Updated to suit Local Highway Authority comments	IZ	GBR	29/03/2021	
A	Updated to suit Safety Audit Comments	IZ	GBR	30/08/2018	
REV	DESCRIPTION	DRN	CHD	DATE	
<input checked="" type="checkbox"/>	PRELIMINARY	<input type="checkbox"/>	INFORMATION	<input type="checkbox"/>	TENDER
<input type="checkbox"/>	CONSTRUCTION	<input type="checkbox"/>	AS BUILT		

SCALE	1:500 @ A2	DATE	August 18
DRAWN	IZ	CHK	GBR
DRAWING NO.	17901-IPSW-5-500	REV	B
TITLE	Land East of Ipswich Road Newton Flotman		
DETAILS	Site Access		

Woods Hardwick
Architecture | Engineering | Planning | Surveying

BEDFORD : HEAD OFFICE
15-17 Goldington Road
Bedford MK40 3NH
T: +44 (0) 1234 268862

BIRMINGHAM
Fort Dunlop, Fort Parkway
Birmingham B24 9FE
T: +44 (0) 121 6297784

ONLINE: mail@woodsardwick.com | woodsardwick.com

PLEASE CONSIDER THE ENVIRONMENT BEFORE PRINTING THIS DRAWING

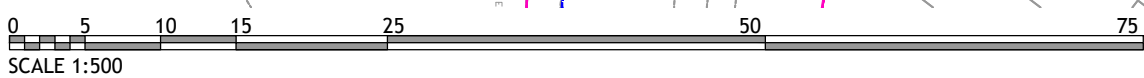

Appendix 2- Landscape and Visual Appraisal



Woods Hardwick

Land off Ipswich Road, Newton Flotman

LANDSCAPE AND VISUAL APPRAISAL

December 2020

FPCR Environment and Design Ltd

Registered Office: Lockington Hall, Lockington, Derby DE74 2RH

Company No. 07128076. [T] 01509 672772 [F] 01509 674565 [E] mail@fpcr.co.uk [W] www.fpcr.co.uk

This report is the property of FPCR Environment and Design Ltd and is issued on the condition it is not reproduced, retained or disclosed to any unauthorised person, either wholly or in part without the written consent of FPCR Environment and Design Ltd. Ordnance Survey material is used with permission of The Controller of HMSO, Crown copyright 100018896.

Rev	Issue Status	Prepared/Date	Approved/Date
	Draft	17/12/2020 MGH	17/12/2020 MGH
	Final	18/12/2020 MGH	18/12/2020 MGH

CONTENTS

1.0 INTRODUCTION..... 2

2.0 METHODOLOGY..... 3

3.0 PLANNING POLICY..... 7

4.0 BASELINE CONDITIONS..... 8

5.0 PROPOSALS.....15

6.0 LANDSCAPE AND VISUAL EFFECTS.....15

7.0 SUMMARY AND CONCLUSIONS.....17

FIGURES

- Figure 1: Site Location and Viewpoints
- Figure 2: Landscape Character
- Figure 3: Designations
- Figure.4-7: Photo viewpoints

APPENDICES

- Appendix A: LVA Methodology and Appraisal Criteria

1.0 INTRODUCTION

- 1.1 This Landscape and Visual Appraisal (LVA) has been carried out for the proposal to construct up to 30 new houses on land east of Ipswich Road, Newton Flotman. The site is currently occupied by a bungalow in poor condition, a range of other buildings and unmanaged garden land. The purpose of this LVA study is to provide an appraisal of the likely landscape and visual effects of the proposed development. The landscape and visual effects have been considered in relation to the proposals detailed on the illustrative plan.
- 1.2 FPCR is a multi-disciplinary environmental and design consultancy with over 60 years' experience of architecture, landscape, ecology, urban design, masterplanning and environmental impact assessment. The practice is a member of the Landscape Institute and Institute of Environmental Management and Assessment and is frequently called upon to provide expert evidence on landscape and visual issues at Public and Local Plan Inquiries.

Site Location

- 1.3 Figure 1 shows the location and context of the site. The site is situated east of the A140 Ipswich Road on the eastern edge of the village. To the north and south are residential properties, mostly set within larger gardens, and to the west is a garage and other residential areas.

Proposed Development

- 1.4 The proposed development is for the construction of up to 30 dwellings as shown on the illustrative drawing 17746/1001A, with access from Ipswich Road.

2.0 METHODOLOGY

2.1 This LVA has been prepared based upon the Guidelines for Landscape and Visual Impact Assessment, third edition (GLVIA3), published by the Landscape Institute and the Institute of Environmental Management and Assessment, in 2013.

2.2 In summary, the GLVIA3 states:

“Landscape and Visual impact assessment (LVIA), is a tool used to identify and assess the significance of and the effects of change resulting from development on both landscape as an environmental resource in its own right and on people’s views and visual amenity.” (GLVIA3 paragraph 1.1.)

2.3 There are two components of LVIA:

- *“Assessment of landscape effects; assessing effects on the landscape as a resource in its own right;*
- *Assessment of visual effects: assessing effects on specific views and on the general visual amenity experienced by people.”* (GLVIA3 paragraph 2.21.)

2.4 The GLVIA3 states:

“LVIA can be carried out either as part of a broader EIA, or as a standalone ‘appraisal’ of the likely landscape and visual effects of a proposed development...”

- *As a standalone ‘appraisal’ the process is informal and there is more flexibility, but the essence of the approach – specifying the nature of the proposed change or development; describing the existing landscape and the views and visual amenity of the area that may be affected; predicting the effects, although not their likely significance; and considering how those effects might be mitigated – still applies”.* (GLVIA paragraph 3.2)

2.5 The components of this report include: baseline studies; description and details of the landscape proposals and mitigation measures to be adopted as part of the scheme; and identification and description of likely effects arising from the proposed development.

2.6 In terms of baseline studies, the assessment provides an understanding of the landscape that may be affected, its constituent elements, character, condition and value. For the visual baseline, this includes an understanding of the area in which the development may be visible, the people who may experience views, and the nature of views.

Assessment of Landscape Effects

2.7 GLVIA3 states that *“An assessment of landscape effects deals with the effects of change and development on landscape as a resource”* (GLVIA3 paragraph 5.1).

2.8 The baseline landscape is described by reference to existing published Landscape Character Assessments and by a description of the site and its context.

2.9 A range of landscape effects can arise through development. These can include:

- Change or loss of elements, features, aesthetic or perceptual aspects that contribute to the character and distinctiveness of the landscape;
- Addition of new elements that influence character and distinctiveness of the landscape;

- Combined effects of these changes.
- 2.10 The characteristics of the existing landscape resource are considered in respect of the susceptibility of the landscape resource to the change arising from this development. The value of the existing landscape is also considered.
- 2.11 Each effect on landscape receptors is assessed in terms of size or scale, the geographical extent of the area influenced and its duration and reversibility. In terms of size or scale of change, the judgement takes account of the extent of the existing landscape elements that will be lost or changed, and the degree to which the aesthetic or perceptual aspects or key characteristics of the landscape will be altered by removal or addition of new elements.
- 2.12 The level of effect is determined by considering the sensitivity of the landscape receptors and the magnitude of effect on the landscape. Final conclusions on the overall landscape effects are drawn from the assessment components described. This appraisal describes the nature of the landscape effects, and whether these are adverse or beneficial, at the following stages of development; construction, completion (year 1) and longer term (year 15).
- 2.13 GLVIA3 sets out some guidance on the underlying principles, which are used in this appraisal. This includes Figure 5.10, Scale of significance. Whilst this scheme is not EIA development, and judgements on significance are not therefore required, the Figure does provide useful guidance on reaching an overall judgement on the level of effects. This is repeated below (note this includes the correction of a typo, from the published document)

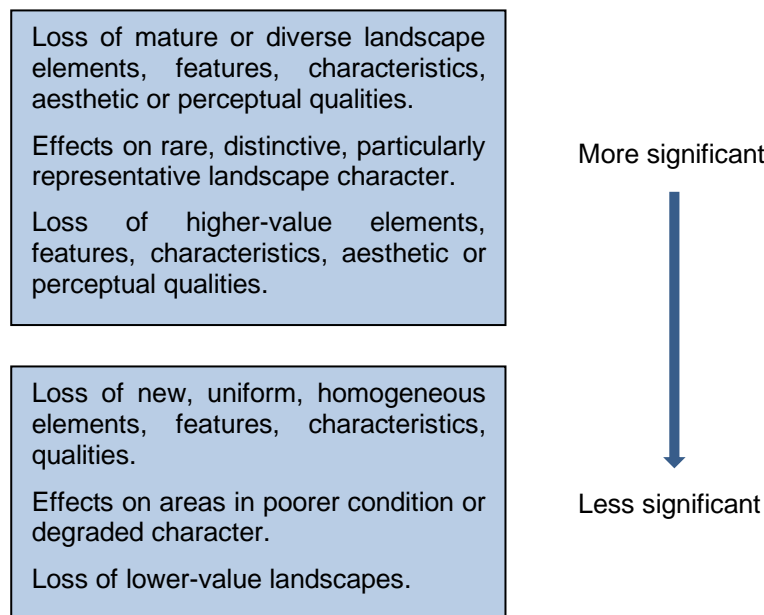

- 2.14 The criteria used in the appraisal are set out in Appendix A.

Assessment of Visual Effects

- 2.15 An assessment of visual effects deals with the effects of change and development on the views available to people and their visual amenity. This appraisal describes the nature of the visual effects and, whether these are adverse or beneficial, at the following stages of development; construction, completion (year 0 Winter) and longer term (year 15 Summer).

- 2.16 The first stage in the assessment is to identify approximate visibility/ visibility mapping. This is done by either a computerised Zone of Theoretical Visibility (ZTV)¹, or by manual methods using map study and field evaluation. A series of viewpoints are included within the assessment that are representative of views towards the site from surrounding visual receptors. Other views of the site are included where it supports the description and understanding of the site's landscape and visual characteristics.
- 2.17 The views also typically represent what can be seen from a variety of distances from the development and different viewing experiences.
- 2.18 It is important to remember that visual receptors are all people. For each affected viewpoint, the assessment considers both the susceptibility to change in views and the value attached to views.
- "The visual receptors most susceptible to change are generally likely to include:*
- *Residents at home;*
 - *People, whether residents or visitors, who are engaged in outdoor recreation, including use of public rights of way, whose attention or interest is likely to be focused on the landscape and on particular views;*
 - *Visitors to heritage assets, or to other attractions, where views of the surroundings are an important contributor to the experience;*
 - *Communities where views contribute to the landscape setting enjoyed by residents in the area;*
- Travellers on road, rail or other transport routes tend to fall into an intermediate category of moderate susceptibility to change. Where travel involves recognised scenic routes awareness of views is likely to be particularly high."* (GLVIA3 paragraph 6.33.)
- "Visual receptors likely to be less sensitive to change include:*
- *People engaged in outdoor sport or recreation which does not involve or depend upon appreciation of views of the landscape;*
 - *People at their place of work whose attention may be focused on their work or activity, not on their surroundings, and where the setting is not important to the quality of working life (although there may on occasion be cases where views are an important contributor to the setting and to the quality of working life)." (GLVIA3 paragraph 6.34.)*
- 2.19 Each of the visual effects is evaluated in terms of its size or scale, the geographical extent of the area influenced and its duration or reversibility.
- 2.20 In terms of size or scale, the magnitude of visual effects takes account of:
- *"The scale of the change in the view with respect to the loss or addition of features in the view and changes in its composition, including proportion of the view occupied by the proposed development;*
 - *The degree of contrast or integration of any new features or changes in the landscape with the existing or remaining landscape elements and characteristics in terms of form, scale and mass, line height, colour and texture;*

¹ Zone of Theoretical Visibility (ZTV): A map usually digitally produced, showing areas of land within which a development is theoretically visible. [GLVIA3]

- *The nature of the view of the proposed development, in terms of the relative amount of time over which it will be experienced and whether views will be full, partial or glimpses” (GLVIA3 paragraph 6.39).*
- 2.21 The geographical extent of the visual effect in each viewpoint is likely to reflect:
- The angle of view in relation to the main activity of the receptor;
 - The distance of the viewpoint from the proposed development;
 - The extent of the area over which the changes would be visible.
- 2.22 As with landscape effects, the duration of the effect could be short to long term or permanent and the same definitions apply.
- 2.23 GLVIA3 states that there are no hard and fast rules about what makes a significant effect, and there cannot be a standard approach since circumstances vary with the location and context and with the type of proposal, but the following points should be noted;
- *Effects on people who are particularly sensitive to changes in views and visual amenity are more likely to be significant*
 - *Effects on people at recognised and important viewpoints or from recognised scenic routes are more likely to be significant*
 - *Large-scale changes which introduce new, non-characteristic or discordant or intrusive elements into the view are more likely to be significant than small changes or changes involving features already present within the view. (GLVIA3 paragraph 6.44)*
- 2.24 The criteria used in this appraisal are set out in Appendix A.

Overall Landscape and Visual Effects

- 2.25 The final conclusions on effects, whether adverse or beneficial, are drawn from the separate judgements on the sensitivity of the receptors and the magnitude of the effects. This overall judgement is formed from a reasoned professional overview of the individual judgements against the assessment criteria.
- 2.26 GLVIA3 notes, at paragraphs 5.56 and 6.44, that there are no hard and fast rules with regard to the level of effects, therefore the following terms have been used for this appraisal:
- **Major**
 - **Moderate**
 - **Minor**
 - **Negligible**
- 2.27 Where it is determined that the assessment falls between or encompasses two of the defined criteria terms, then the judgement may be described as, for example, Major/ Moderate or Moderate/ Minor. This indicates that the effect is assessed to lie between the respective definitions or to encompass aspects of both.

3.0 PLANNING POLICY

National Planning Policy

National Planning Policy Framework (NPPF, February 2019)

- 3.1 The NPPF sets out the Government's economic, environmental and social planning policy and in combination these policies give the Government's vision of sustainable development. The NPPF emphasises the need for well-designed places, promoting healthy and safe communities and conserving and enhancing the natural environment.
- 3.2 Paragraph 170 states at part a) that planning policies and decisions should protect and enhance valued landscapes and goes on to clarify that this should be in a manner commensurate with their statutory status or identified quality in the development plan. Part b) states that planning policies and decisions should recognise *"the intrinsic character and beauty of the countryside"*.
- 3.3 Paragraph 171 advises that:
"Plans should: distinguish between the hierarchy of international, national and locally designated sites; allocate land with the least environmental or amenity value, where consistent with other policies in this Framework; take a strategic approach to maintaining and enhancing networks of habitats and green infrastructure; and plan for the enhancement of natural capital at a catchment or landscape scale across local authority boundaries".
- 3.4 Paragraph 172 goes on to add:
"Great weight should be given to conserving and enhancing landscape and scenic beauty in National Parks, the Broads and Areas of Outstanding Natural Beauty, which have the highest status of protection in relation to these issues".
- 3.5 The site is within an undesignated landscape with no special protected status. The character of the site and its immediate context is assessed within this report to help inform decisions regarding *"the intrinsic character and beauty of the countryside"*.

Planning Practice Guidance (PPG)

- 3.6 The PPG was first published on 6th March 2014 and is a regularly updated online planning resource which provides guidance on the NPPF and the planning system. The NPPF continues to be the primary document for decision making.

Local Planning Policy

South Norfolk Local Plan - Development Management Policies Document October 2015.

- 3.7 Previous consultation with South Norfolk Council highlighted policies DM1.3 and Policies DM4.5 from the Development Management Policies document, as of relevance to the site.

Policy DM1.3 The sustainable Location of new Development

- 3.8 This states that;

1) All new development should be located so that it positively contributes to the sustainable development of South Norfolk as led by the Local Plan. The Council will work with developers to promote and achieve proposals that are:

(a) Located on Allocated Sites or within the development boundaries of Settlements defined on the Policies Map, comprising the Norwich Fringe, Main Towns, Key Service Centres, Service Villages and Other Villages; and

(b) Of a scale proportionate to the level of growth planned in that location, and the role and function of the Settlement within which it is located, as defined in the Local Plan.

2) Permission for development in the Countryside outside of the defined development boundaries of Settlements will only be granted if:

c) Where specific Development Management Policies allow for development outside of development boundaries or

d) Otherwise demonstrates overriding benefits in terms of economic, social and environment dimensions as addressed in Policy 1.1.

Policy DM 4.5 Protection and Enhancement of Landscape Character

This policy states;

All development should respect, conserve and where possible, enhance the landscape character of its immediate and wider environment. Development proposals that would cause significant adverse impact on the distinctive landscape characteristics of an area will be refused.

All development proposals will be expected to demonstrate how they have taken the following elements (from the 2001 South Norfolk Landscape Assessment as updated by the 2012 review) into account:

- The key characteristics, assets, sensitivities and vulnerabilities;
- The landscape strategy; and
- Development considerations.

Particular regard will be had to protecting the distinctive characteristics, special qualities and geographical extents of the identified Rural River Valleys and Valley Urban Fringe landscape character types.

3.9 The site lies within an area identified as River Valley and this is shown on Figure 3 of this report.

4.0 BASELINE CONDITIONS

Landscape Character

National Character

4.1 National Character Area (NCA) profiles have been prepared by Natural England for the 159 NCAs defined across England. These NCA profiles include a description of the natural and cultural features that shape the landscape, how the landscape has changed over time, the current key drivers for ongoing change, and a broad analysis of each area's characteristics.

NCA 83 South Norfolk and High Suffolk Claylands

4.2 The site and the wider landscape are located within the South Norfolk and High Suffolk Claylands NCA. This covers a very broad area. The key characteristics of this Character Area are defined below:

- *Large plateau area of chalky glacial till that is generally flat or only gently undulating, but can be locally concave. The edges of the plateau have been dissected by watercourses that form greater slopes, especially along the tributaries of the Waveney.*
- *Views are frequently open, only sometimes confined by hedges and trees, with some woodland present. The small valleys support quite confined landscapes with intimate views.*
- *Chalk bedrock overlain by glacial till, gravels and sands. Heavy, seasonally waterlogged chalky clay soils occur on the plateau, with small areas of better soils at the edges. The valley bottoms contain areas of glacial outwash deposits as well as some areas of deep peat.*
- *Scattered areas of ancient woodland, game copses, shelterbelts, valley floor plantation and carr woodland as well as hedgerow trees provide a treed landscape character, despite much boundary loss.*
- *A mix of remnant medieval ancient countryside, some of it with a decidedly coaxial character, although irregular field patterns and large modern amalgamated open fields dominate.*
- *Sinuuous field boundaries are formed by deep ditches, some with hedgerows and hedgerow trees.*

South Norfolk Landscape Character Assessment 2004

4.3 This study provides an integrated view of the landscape of south Norfolk. A range of character areas are identified and described and those in the vicinity of the site are shown on Figure 2. The site lies within an area described as A1 "Tas Rural River Valley".

A1: TAS RURAL RIVER VALLEY

The key characteristics for this area are described:

4.4 Key Characteristics

- Distinct, moderately wide simple valley form with medium-scale clearly defined flat valley floor, shallow side slopes and adjoining smaller-scale tributary valleys.
- Less enclosed than some other valleys with a feeling of exposure and openness and some long views within the valley but restricted external views.
- River alternately visible and hidden marked by sparse waterside vegetation including reed filled ditches and narrow woodland belts. The flat, wide, green valley floor is a distinctive feature.
- A large number of attractive fords and small bridges occurring at regular intervals along the river and side tributaries.
- Pastoral valley floor with cattle grazing and distinctive willow pollards lining the watercourses on the valley floor.
- Upper tributary valleys of great ecological richness and importance, including areas of fen, marsh and unimproved wet and neutral grassland.

- Fragmented woodlands and shelterbelts on the valley sides creating a wooded fringe to much of the valley interspersed with more open areas of arable land.
- Presence of historic earthworks including Scheduled Ancient Monuments, including the large highly visible defensive earthworks of Venta Icenorum and the earthworks at Tasburgh.
- Sparsely settled character with buildings clustered around fording points and at the top of the valley sides.
- Characteristic vernacular buildings particularly notably including weather boarded mill houses and Dutch gable ends.
- Presence of a small number of distinctive halls and parkland including English Heritage listed parkland at Rainthorpe Hall.
- Network of narrow peaceful rural lanes throughout the valley including sunken lanes.
- A more disturbed character in the north of the area due to the influence of pylons, railway and roads.
- Role in dividing and defining east and west of South Norfolk District.

4.5 The study includes a section on Sensitivities and Vulnerabilities which include;

- *the peaceful rural character of the Tas Valley and the sensitivities to incremental small scale change, including upgrading of the rural lane network (e.g. kerbing would be very detrimental to the character of the sunken lanes which are a feature of the valley, with their small fords and river crossings);*
- *particular vulnerabilities in the northern part of the valley due to the impact of infrastructure and large scale land uses relating to the urban edge of Norwich including pylons, golf courses and development in association with the transport corridors (A140 and A47);*
- *visual sensitivities of the Tas Valley to new development/landscape change as a result of its open character, wide flat floor and long valley views, plus importance of valley crests;*
- *loss of hedgerow boundaries and trees, resulting in a further opening up of the landscape creating some very large scale and bleak areas on valley sides;*
- *small scale development pressures (infill, residential extensions) within the valley which could, over time, erode the local rural vernacular and the sense that buildings are well-integrated within the landscape context;*
- *sensitivity of historic landscapes, particularly Caistor St. Edmund to visual intrusion.*

4.6 The study also includes a section on “Development Considerations”. This states that;

Any development must respect the character of the Tas Rural River Valley and conserve and enhance the key landscape assets as described in the landscape character assessment. In particular it must seek to maintain the peaceful rural qualities of the valley. This will include reference to the following considerations:

- *respect the sparsely settled character of the valley, with its occasional buildings of local rural vernacular character, with a clear relation to the landscape context;*
- *maintain the distinctive settlement pattern, either nucleated around bridges or around ford crossing points or as linear settlements along roads on the valley sides. The objective should*

be to maintain the linear settlements (e.g. Stoke Holy Cross) as discrete areas and prevent gradual and incremental extension along the roads;

- *consider the impact of developments within the adjacent landscape character areas, particularly the higher land of the Tas Tributary Farmland (character area B1) on the character of the rural valley. The openness of parts of the valley and views that can be obtained make it particularly vulnerable;*
- *ensure that the northern part of the Tas Valley is not further degraded, by large scale of infrastructure developments associated with the roads. Ensure the rural character of the area adjacent to the Norwich Southern Bypass is maintained;*
- *consider the impact of any proposals on the rural lane network;*
- *maintain the role of the sparsely-settled Tas Valley in dividing the more settled areas to the east and west and avoid developments that may create the impression of developed corridors running across the valley.*

Designations

- 4.7 There are no national or local landscape designations such as National Parks, AONB`s, or Special Landscape Areas, in the vicinity of the site. Land to the north of the village forms part of the very large Shotesham Conservation area. The land to the east of the site was previously also in this conservation area and is shown as such in the local Plan. The 2018 Conservation Area Appraisal, produced by the council confirmed (page 5) that

“As part of this appraisal, the boundaries have been reviewed, and some amendments are suggested. It is considered that there are some parts of the current conservation area which may not be eligible under the legal definition and in the light of recent guidance. Some of the land between Shotesham Park and The Old Hall is essentially rural farmland without any clear “special architectural or historic interest”, which does not make a significant contribution to the setting of either listed building. The extent of the area around Shotesham Park could be reduced to omit land around Smockmill Common and land west of the Tas at Dairy Farm which do not seem to form an obvious part of the historic parkland.”

- 4.8 The Conservation Area shown on Figure 3 accords with the boundary from the 2018 Conservation Area Appraisal. The site lies within an area described as “River Valleys” in the Local plan. This is also shown on Figure 3.

Topography

- 4.9 The site and village forms part of the Tas Valley. The topography is relatively gentle and the land within the site is at approximately 20m AOD.

Site and Immediate Context

- 4.10 An assessment of landscape character of the site and its immediate context has been carried out, providing a finer level of assessment than the published studies. The site itself is an existing bungalow and some other buildings along with unused garden land. In character terms, the site forms part of the village, with a range of development both sides of Ipswich Road. To the west of the road, there is an extensive area of mostly modern residential development, with a garage

opposite the site. To the east of Ipswich Road, the character is more varied, with some individual properties some set in larger gardens and some more open areas, such as near the river to the south. There are some areas of development in greater depth, such as at Kingsway.

Landscape Value

- 4.11 In terms of "landscape value" it is appropriate to examine the role of the site and its immediate context in terms of the range of local factors set out in the GLVIA3 (Box 5.1, page 84), and summarised in the methodology. The section below considers the landscape in terms of a range of factors as set out. As a starting point, landscape designations have been considered.

Landscape Designations:

- 4.12 The site and its wider landscape context is not subject to any national, local or other landscape designations. The Conservation Area, to the north, does not influence the sites immediate context.

Landscape Quality (Condition):

- 4.13 The site itself is used as an area of unused garden and existing buildings in poor repair. There is no vegetation of particular value. The overall condition is poor.

Scenic Quality:

- 4.14 The site itself is of low scenic quality and makes very little contribution to the surrounding area. The wider woodland to the east and the centre of the village and church are more attractive.

Rarity and Representativeness:

- 4.15 The site itself is not a rare landscape, and the immediate townscape is pleasant but not particularly rare or representative.

Conservation Interest:

- 4.16 There are no features of conservation value on the site. The Conservation Area lies to the north but separated by existing residential development and planting. Smockmill Common to the east is of some Conservation value, but is a very different landscape to the site.

Recreational Value:

- 4.17 The site itself has no recreational value. There is the potential through site redevelopment to provide part of a new pedestrian recreational link to Smockmill Common.

Perceptual Aspects

- 4.18 The presence of the A 140 means that the site is not wild or tranquil, which are the characteristics identified in the guidance.

Associations:

- 4.19 There are no known associations with writers or artists. In conclusion and having appraised the above factors it is judged that the site and the immediate landscape is of medium/low landscape value. This is judged not to be a "Valued landscape" as paragraph 170a of the NPPF.

Visual Baseline

- 4.20 A visual appraisal has been undertaken for the site. This has explored the nature of the existing visual amenity of the area and sought to establish the approximate visibility of the site from surrounding locations and receptors. A series of photo viewpoints have been selected which support this analysis.
- 4.21 Photographs have been taken to illustrate a view from a specific vantage point, or to demonstrate a representative view for those receptors that are moving through the landscape and village. There are also viewpoints to show the site itself. The photographs may demonstrate varying degrees of visibility and include both short and long-range views. Seasonal differences have been taken into account when determining the visual effects on receptors.
- 4.22 'Photo Viewpoints', as referred to in this report are 'Type 1 Visualisations' or 'Annotated Viewpoint Photographs', as referred to in the Landscape Institute Technical Guidance Note on 'Visual Representation of Development Proposals' (TGN 06/19).

Photo Viewpoints

- 4.23 An assessment of the likely visual effects of the proposed development upon surrounding receptors is detailed in the subsequent section. Figure 1 details the location of the Photo Viewpoints and Figures 4 to 7 illustrate the photo viewpoints. They are briefly described below.

Viewpoint 1

- 4.24 This viewpoint is located within the site (not a public viewpoint) and shows a view back towards Ipswich Road. The degraded nature of the site can be seen. The garage opposite the site can be seen along the access track.

Viewpoint 2

- 4.25 This viewpoint is located on the verge to Ipswich Road. It again shows the poor condition of the site, with the range of buildings and unmanaged land.

Viewpoint 3

- 4.26 Viewpoint 3 shows a view south along Ipswich Road, from close to the church. At this point you feel that you are within the village. Residential development lies to the east of Ipswich Road, but the tall boundary hedgerow is the most visible feature. Only planting on the site frontage is visible from here.

Viewpoint 4

- 4.27 This view from the end of St Marys Close, looks across the A140 to the site. The bungalows and outbuildings can be seen, along with some limited views to the housing north of the site and the woodland to the east.

Viewpoint 5

- 4.28 Located at the end of Flordon Road, this viewpoint shows a view across the green within the village towards the site. Most of the hedge seen opposite the green, belongs to the residential properties

south of the site. Within the site the existing bungalow can be seen, along with a short section of site frontage.

Viewpoint 6

- 4.29 Viewpoint 6 is located on Ipswich Road at the junction with Short Street. The site and part of the site frontage is visible, between the existing bungalow and the gate. The majority of the garden vegetation seen beyond the road belongs to the residential property south of the site.

Viewpoint 7

- 4.30 The view along the A140 Ipswich Road from the bridge over the River Tas, shows the vegetation along the side of the river and a view towards the village centre the site is not visible.

Summary of Visual Baseline

- 4.31 The baseline analysis results in a number of reasoned conclusions which are summarised below:
- The site itself is visually well contained by development in the village, to the north west and south. Land east of the site is mostly wooded, and currently has no public access, limiting any potential views from this direction.
 - Any views to the site are from within the village itself, from the A140 Ipswich Road and the roads that lead from it.
 - Where the site can be seen, the existing buildings on it and the unmanaged land, present a rather neglected appearance, having a negative effect on the overall townscape.

5.0 PROPOSALS

- 5.1 The development proposals are shown on the indicative scheme drawing (17746/1001A) prepared by Woods Hardwick. The scheme is for up to 30 new dwellings. The existing buildings would be demolished, and a comprehensive redevelopment could take place. Following input from this appraisal, the scheme has been developed with a small number of larger properties facing Ipswich Road, this is to reflect the character of some of the other properties to the east of the road. The houses would be set back behind the retained hedge boundary, supplemented by additional planting including trees. Beyond the first row of larger properties, the site could accommodate more smaller properties, without adverse effects on the wider character.
- 5.2 There is also the opportunity to provide a pedestrian link through the site to land beyond, which could provide a pedestrian route between the centre of the village and Smockmill Common. The Common is a local nature reserve and popular place for recreation. Currently access is via Cargate Lane, which is a relatively narrow road with no footways. This existing route is not attractive for pedestrian use. Providing a new non-vehicular route to the Common, would be a clear benefit.

6.0 LANDSCAPE AND VISUAL EFFECTS

- 6.1 The following section outlines the likely landscape and visual effects that would arise from proposed development on the site.

Landscape Effects

- 6.2 The site and the immediate landscape are located within the NCA 83 South Norfolk and High Suffolk Claylands. This covers a very extensive area. At this scale the magnitude of landscape change arising from the construction of up to 30 new properties within an existing garden area would be negligible, as would the overall landscape effects. There would be no material change to the key characteristics that define the NCA.
- 6.3 Within South Norfolk, the site is in the Character Area described as the Tas Rural River Valley. This is predominantly a valley landscape with some open areas and some areas that are much more wooded. Whilst the site lies within this area, it is already developed and in character is part of the existing village. The landscape character assessment identifies “*Sensitivities and Vulnerabilities*” and one of these is “*visual sensitivities*” as a result of open character. The site here is not vulnerable as it does not have an open character, being enclosed from the wider landscape by existing woodland. Another identified Vulnerability is “*small scale development pressures (infill, residential extensions) within the valley which could, over time, erode the local rural vernacular and the sense that buildings are well-integrated within the landscape context*”. The site does not contain any features of “*local vernacular*” that would be lost, and the site is already developed. A new scheme could contribute more to local character.
- 6.4 The assessment also includes a section on “Development Considerations” and states that “*Any development must respect the character of the Tas Rural River Valley and conserve and enhance the key landscape assets as described in the landscape character assessment. In particular it must seek to maintain the peaceful rural qualities of the valley*”. It goes on to note that maintaining the distinctive settlement pattern, either nucleated or linear is one of these objectives. Newton Flotman is a nucleated settlement, and the site is already part of the existing settlement pattern, with residential development north west and south of it. There would be no change to the overall pattern of settlement form arising from development of this site.

- 6.5 Overall, there would be a very minor/negligible change to the landscape area as a whole arising from the development of this site.
- 6.6 Within the site and its immediate context there would inevitably be a greater degree of change, and the character would become more developed. By including a small number of mainly larger properties to the road frontage, the character of the village at this point would be maintained. There is already development east of Ipswich Road in depth, and the development of this site would not change that.
- 6.7 The development would be set back from the eastern boundary and the River Tas, with an area of green space including sustainable drainage. This arrangement would make an attractive interface with the more rural area to the west, though any effects would be very restricted due to the mature woodland and trees which enclose the site in this direction.
- 6.8 The overall character of the village and particularly around the Green near Ipswich Road would remain as an attractive space, but with the bungalow and other buildings removed and replaced. The overall landscape/ townscape effects would be no greater than minor.

Visual Effects

Residential Properties and Settlement

- 6.9 The site is located within the village in character terms, with existing properties to the north south and west. The neighbouring properties to the north and south are largely enclosed by mature garden vegetation, with few views to the site itself. Some views to the existing rather unattractive buildings are possible. If the site is developed, then some views to new houses could be possible. The effects are predicted to be broadly neutral for the neighbours to the north and south.
- 6.10 Views are also possible to the site from the properties west of the A140. At present these views are across the green and the A140 road and include the existing buildings on site. The new buildings and landscape frontage would be seen, but with appropriate design could be a positive addition to the village. The visual effects could again be neutral.

Public Rights of Way (PROW)

- 6.11 There are no rights of way in the vicinity of the site, with views to it. There are routes within Smockmill Common that appear well used by people, but these are mostly within woodland, or not close to the site, so no views are predicted to be affected.
- 6.12 Overall the development of the site would not have any adverse effects on users of public footpaths or bridleways. There is the opportunity described earlier, for a new pedestrian link to Smockmill Common through the site.

Roads & Transport Users

- 6.13 The A140 passes to the west of the site with access to the site from it. This is a relatively busy road. By the time any users are aware of the site, they are within the village, and area aware of housing and other development. Development of the site would give a slightly more developed appearance but could be in character with the wider village. The development would not visually extend the village, as there is already residential development all around it from the A140. There would be a broadly neutral visual effect for road users.

- 6.14 Similar effects would be experienced for users of other roads in the village such as St Marys Close, Short Street, and Old Street, but no views from any more rural roads would be possible.

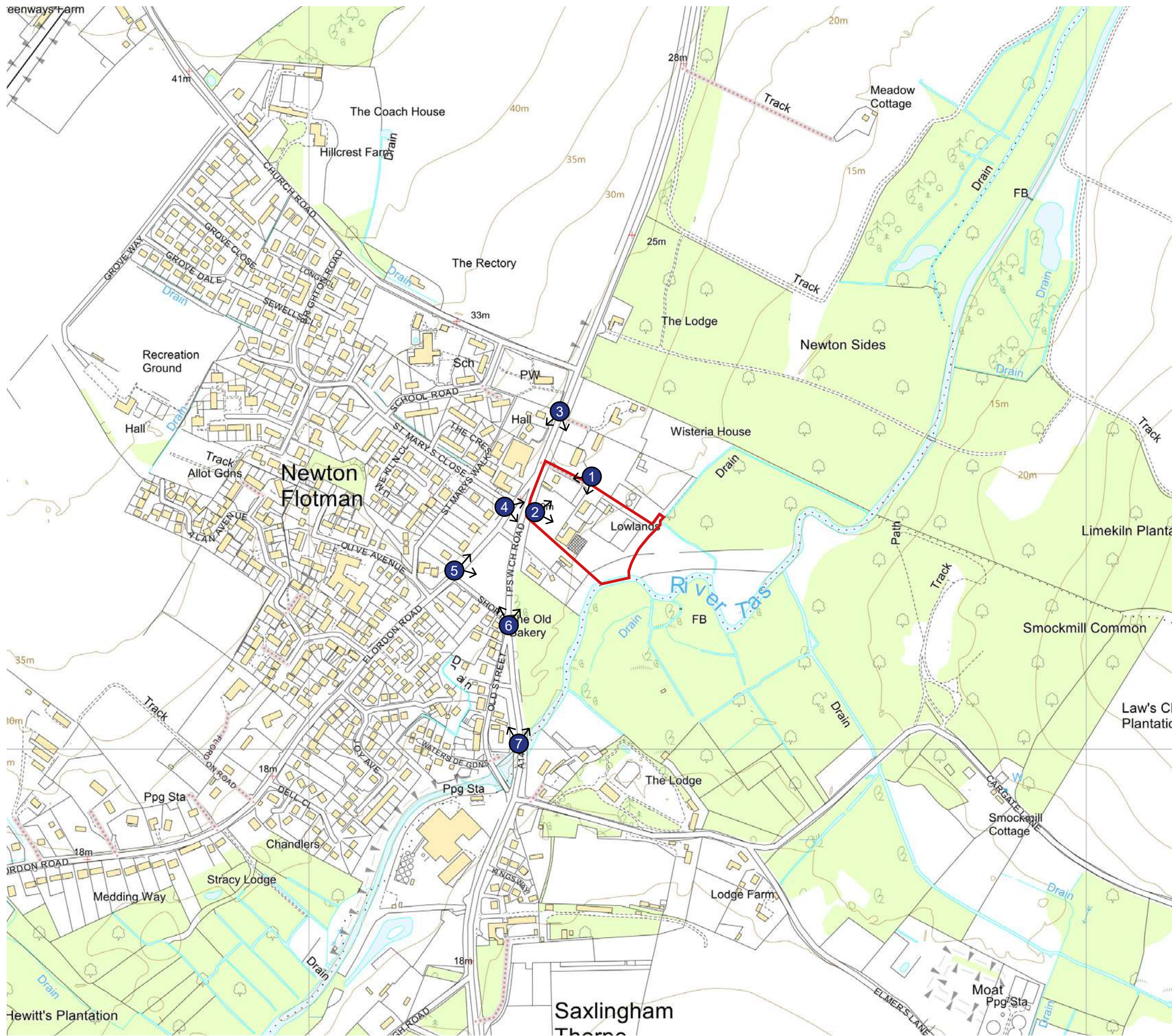

7.0 SUMMARY AND CONCLUSIONS

- 7.1 This Landscape and Visual Appraisal (LVA) has been carried out for the potential development of up to 30 dwellings at Lowlands, Newton Flotman. The site currently contains a number of buildings in a relatively poor condition, along with some unmanaged open areas. The site lies on the eastern side the A140 Ipswich Road Newton Flotman, with existing residential development to the north west and south. Newton Flotman is a nucleated settlement.
- 7.2 In the vicinity of the site, development includes some 20th century properties, overlooking a green between Flordon Road and Ipswich Road and some individual properties mostly in larger gardens to the east of the road. There is development in depth east of Ipswich Road at Kingsway.
- 7.3 The scheme would be a modest addition to the village on a site that is already developed and is to a large degree already screened or softened by the existing garden planting. The scheme could be sensitively designed providing an attractive edge to the wider countryside to the east. Across the wider character area, there would be a minor/ negligible landscape effect.
- 7.4 Within the site and its immediate context, there would inevitably be a greater effect however within the site itself there is little of intrinsic landscape interest or value. An area of existing buildings and garden would be developed for up to 30 dwellings. The frontage would be developed with three larger properties set back behind a hedge and trees. There would be a very little change on the immediate context through change in character.
- 7.5 Visually the site is quite well enclosed with existing property to the north west and south, with woodland to the east. There would be some views from existing houses in the village, from the A140 and other roads close by, but no views from public rights of way. The visual effects would be very limited and localised.
- 7.6 Policy DM 4.5 of the South Norfolk Local Plan covers "Protection and Enhancement of Landscape Character". This policy aims to respect, conserve and where possible, enhance the landscape character. The policy states that proposals that would cause significant adverse impact on the distinctive landscape characteristics of an area will be refused. Reference is made to the South Norfolk Landscape Assessment. This appraisal has shown how the site could be developed in accordance with the guidance on the character assessment, and without causing significant adverse effects.
- 7.7 Overall, the scheme would comprise a modest addition to the village, in a location that already feels to be part of the village and is already developed. The scheme would fit with the existing character and form of the settlement and would have a very limited effect on the landscape or visual amenity beyond the site itself.



This drawing is the property of FPCR Environment and Design Ltd and is issued on the condition it is not reproduced, retained or disclosed to any unauthorised person, either wholly or in part without written consent of FPCR Environment and Design Ltd.

Ordnance Survey material - Crown Copyright. All rights reserved. Licence Number: 100019980 (Centremapslive.com)

 Site Boundary
 Photo Viewpoints with reference

client
Woods Hardwick
 project
Land off Ipswich Road, Newton Flotman
 drawing title
SITE LOCATION AND VIEWPOINTS
 scale
 1:5,000 @ A3
 drawing / figure number
Figure 1
 drawn
 HGK
 issue date
 December 2020
 rev
 -





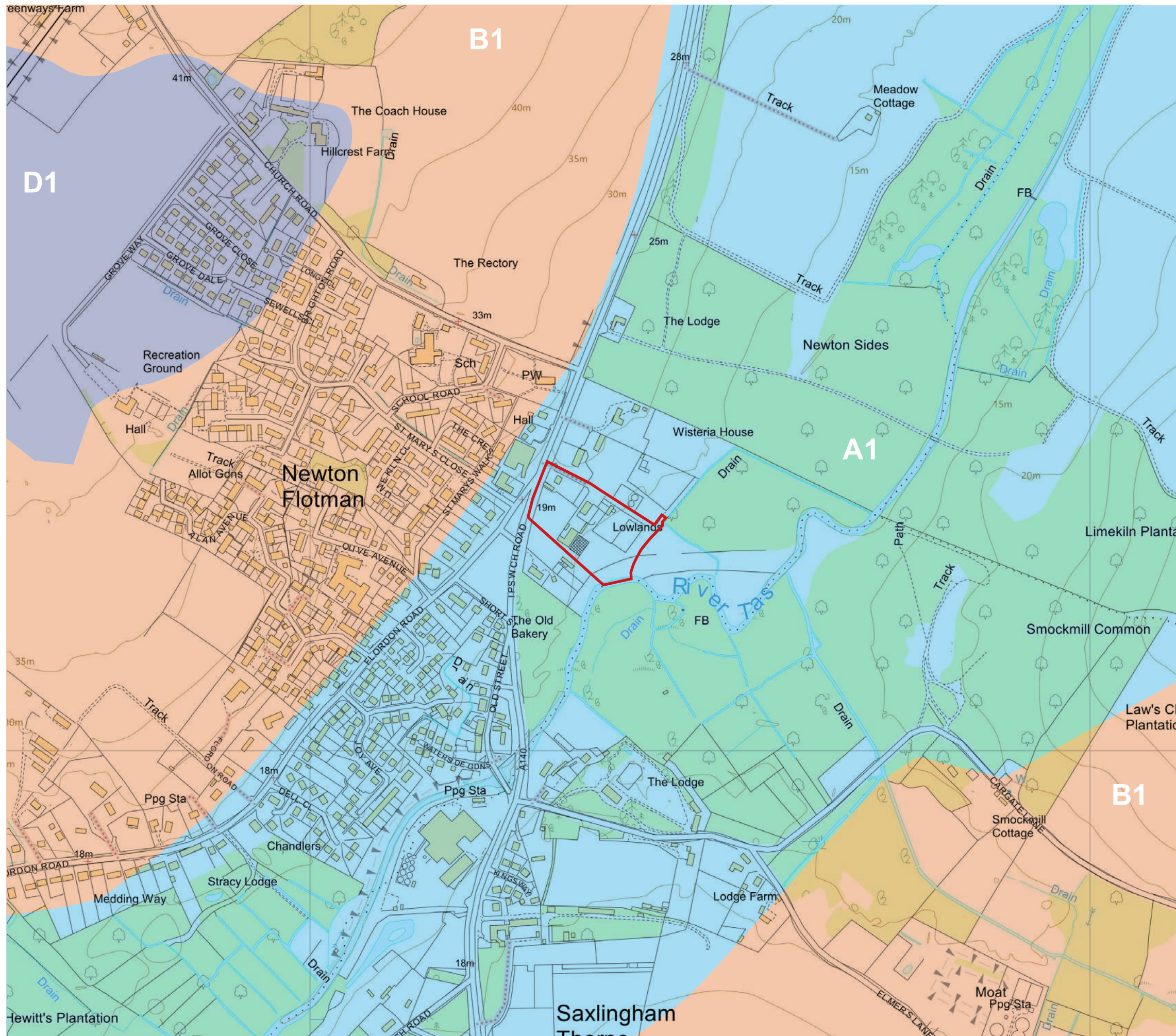



Scale: 1:5000 @ A3





This drawing is the property of FPCR Environment and Design Ltd and is issued on the condition it is not reproduced, retained or disclosed to any unauthorised person, either wholly or in part without written consent of FPCR Environment and Design Ltd.

Ordnance Survey material - Crown Copyright. All rights reserved. Licence Number: 100019980 (Centremapslive.com)

-  Site Boundary
- South Norfolk Local Landscape Designations Review (September 2012)**
-  Rural River Valley (LCT)
-  Tributary Farmland (LCT)
-  Settled Plateau Farmland (LCT)
-  National Character Area (NCA) 83
-  A1: Tas Rural River Valley (LCA)
-  B1: Tas Tributary Farmland (LCA)
-  D1: Settled Plateau Farmland (LCA)

NOTE: National Character Area (NCA) 83: South Norfolk and High Suffolk Claylands covers all mapping extents shown.

client
Woods Hardwick

project
Land off Ipswich Road,
Newton Flotman

drawing title
LANDSCAPE CHARACTER

scale
1:5,000 @ A3

drawn
HGK

issue date
November 2020

rev
-

Figure 2



Scale: 1:5000 @ A3

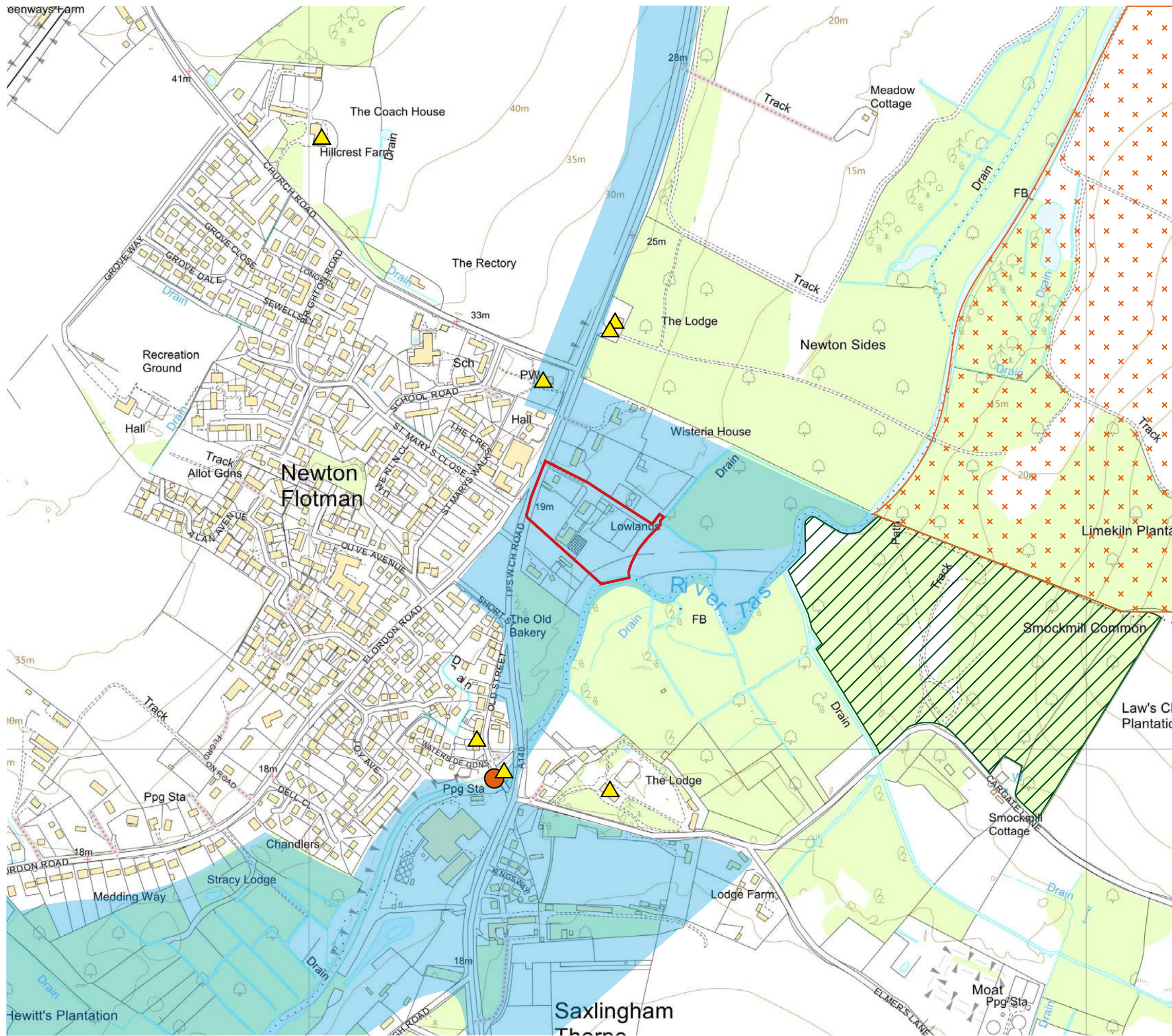





This drawing is the property of FPCR Environment and Design Ltd and is issued on the condition it is not reproduced, retained or disclosed to any unauthorised person, either wholly or in part without written consent of FPCR Environment and Design Ltd.

Ordnance Survey material - Crown Copyright. All rights reserved. Licence Number: 100019980 (Centremapslive.com)

-  Site Boundary
-  Listed Buildings

South Norfolk Local Plan (October 2015)

-  Local nature Reserve
-  Scheduled monument

South Norfolk Development Management Policies

-  Policy DM 4.5 'River Valleys'

Shotesham Conservation Area Character Appraisal and Management Guidelines (December 2018)

-  Conservation Area

client
Woods Hardwick

project
Land off Ipswich Road,
Newton Flotman

drawing title
DESIGNATIONS

scale
1:5,000 @ A3

drawn
HGK

issue date
December 2020



Figure 3

Scale: 1:5000 @ A3

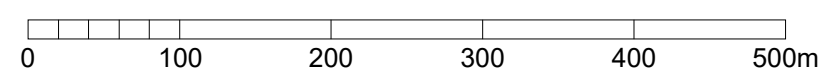
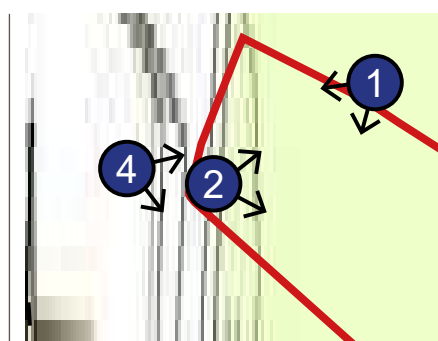
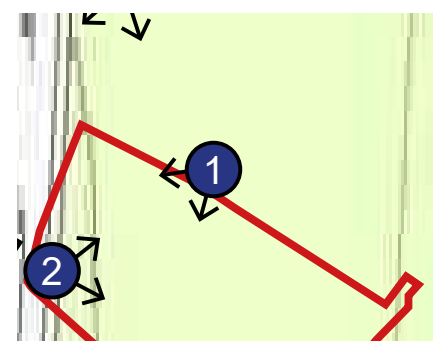



Photo Viewpoint 1: View of existing bungalow within the site.



Photo Viewpoint 2: View of existing site from Ipswich Road.



Printing note: To give the correct viewing distance the sheet should be printed at a scale of 1:1 on A1. To be viewed at comfortable arms length.

Visualisation Type: Type 1
Projection: Cylindrical
Enlargement factor: 100%

This drawing is the property of FPCR Environment and Design Ltd and is issued on the condition it is not reproduced, retained or disclosed to any unauthorised person, either wholly or in part without written consent of FPCR Environment and Design Ltd. Ordnance Survey material - Crown Copyright. All rights reserved. Licence Number: 100019980 (Centremapsive.com)

Site location



Photo Viewpoint 3: View south along Ipswich Road towards the site.

Bungalow within the site

Other buildings within the site



Photo Viewpoint 4: View south east from St Marys Close.

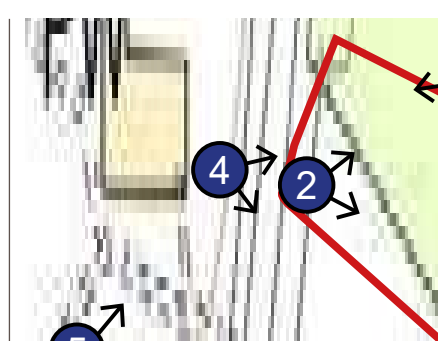
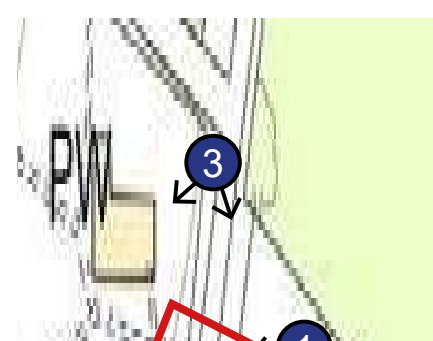

Printing note: To give the correct viewing distance the sheet should be printed at a scale of 1:1 on A1. To be viewed at comfortable arms length.

Visualisation Type: Type 1
Projection: Cylindrical
Enlargement factor: 100%

This drawing is the property of FPCR Environment and Design Ltd and is issued on the condition it is not reproduced, retained or disclosed to any unauthorised person, either wholly or in part without written consent of FPCR Environment and Design Ltd. Ordnance Survey material - Crown Copyright. All rights reserved. Licence Number: 100019980 (Centremapsive.com)

Bungalow within the site

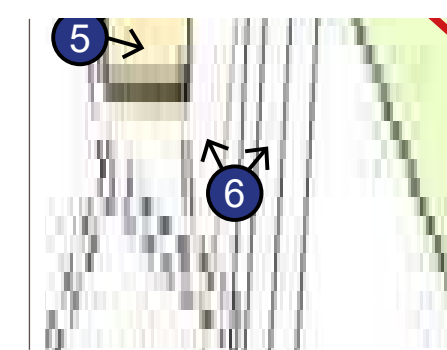
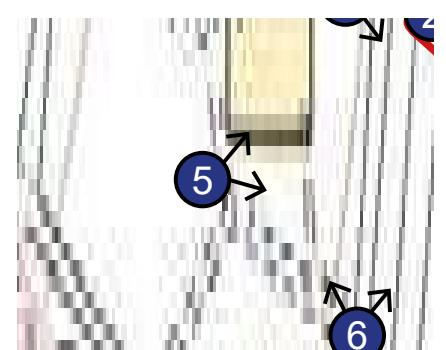

Photo Viewpoint 5: View east from Flordan Road.

Bungalow within the site



Photo Viewpoint 6: View north from Ipswich Road.



Printing note: To give the correct viewing distance the sheet should be printed at a scale of 1:1 on A1. To be viewed at comfortable arms length.

Visualisation Type: Type 1
Projection: Cylindrical
Enlargement factor: 100%

This drawing is the property of FPCR Environment and Design Ltd and is issued on the condition it is not reproduced, retained or disclosed to any unauthorised person, either wholly or in part without written consent of FPCR Environment and Design Ltd. Ordnance Survey material - Crown Copyright. All rights reserved. Licence Number: 100019980 (Centremapslive.com)



Photo Viewpoint 7: View north from Ipswich Road.

I:\FPCR\Map\Map\WoodsHardwick\LANDS\LANDS801 - Figure 4 - Photo Viewpoints.indd

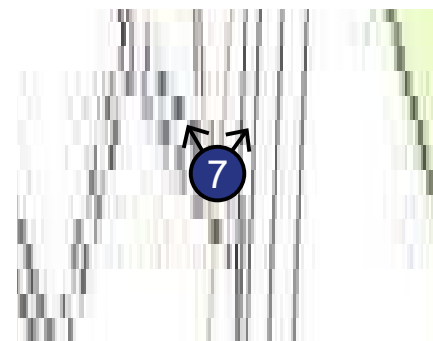

Printing note: To give the correct viewing distance the sheet should be printed at a scale of 1:1 on A1. To be viewed at comfortable arms length.

Visualisation Type: Type 1
Projection: Cylindrical
Enlargement factor: 100%

This drawing is the property of FPCR Environment and Design Ltd and is issued on the condition it is not reproduced, retained or disclosed to any unauthorised person, either wholly or in part without written consent of FPCR Environment and Design Ltd. Ordnance Survey material - Crown Copyright. All rights reserved. Licence Number: 100019980 (Centremapslive.com)

Appendix A

Landscape and Visual Appraisal – Methodology and Assessment Criteria

Introduction

- 1.0 The methodology for the Landscape and Visual Appraisal (LVA) undertaken for the proposed development is detailed in the LVA report. The following information should be read in conjunction with this methodology.
- 1.1 As advised in the Guidelines for Landscape and Visual Impact Assessment (3rd Edition) (GLVIA3), the judgements made in respect of both landscape and visual effects are a combination of an assessment of the sensitivity of the receptor and the magnitude of the landscape or visual effect. The following details the definitions and criteria used in assessing sensitivity and magnitude for landscape and visual receptors.
- 1.2 Where it is determined that the assessment falls between or encompasses two of the defined criteria terms, then the judgement may be described as High/ Medium or Moderate/ Minor etc. This indicates that the assessment lies between the respective definitions or encompasses aspects of both.

Landscape

Landscape Sensitivity

- 1.3 Landscape receptors are assessed in terms of their 'Landscape Sensitivity'. This combines judgements on the value to be attached to the landscape and the susceptibility to change of the landscape from the type of change or development proposed. The definition and criteria adopted for these contributory factors is detailed below.
- 1.4 There can be complex relationships between the value attached to landscape receptors and their susceptibility to change which can be especially important when considering change within or close to designated landscapes. For example, an internationally, nationally or locally valued landscape does not automatically or by definition have a high susceptibility to all types of change. The type of change or development proposed may not compromise the specific basis for the value attached to the landscape.

Landscape Value

- 1.5 Value can apply to a landscape area as a whole, or to the individual elements, features and aesthetic or perceptual dimensions which contribute to the character of the landscape. The following criteria have been used to categorise landscape value. Where there is no clear existing evidence on landscape value, an assessment is made based on the criteria/ factors identified below (based on the guidance in GLVIA3 paragraph 5.28, Box 5.1).

- Landscape quality (condition)
- Scenic quality
- Rarity
- Representativeness
- Conservation interest
- Recreation value
- Perceptual aspects
- Associations

Landscape Value	Definition
High	Landscape receptors of high importance based upon factors of quality, rarity, representativeness, conservation interest, recreational value, perceptual qualities and associations.
Medium	Landscape receptors of medium importance based upon factors of quality, rarity, representativeness, conservation interest, recreational value, perceptual qualities and associations.
Low	Landscape receptors of low importance based upon factors of quality, rarity, representativeness, conservation interest, recreational value, perceptual qualities and associations.

Landscape Susceptibility to Change

- 1.6 This means the ability of the landscape receptor (overall character type/ area or individual element/ feature) to accommodate the change (i.e. the proposed development) without undue consequences for the maintenance of the baseline position and/ or the achievement of landscape planning policies and strategies. The definition and criteria for the assessment of Landscape Susceptibility to Change is as follows:

Landscape Susceptibility to Change	Definition
High	A highly distinctive and cohesive landscape receptor, with positive characteristics and features with no or very few detracting or intrusive elements. Landscape features intact and in very good condition and/ or rare. Limited capacity to accept the type of change/ development proposed.
Medium	Distinctive and more commonplace landscape receptor, with some positive characteristics/ features and some detracting or intrusive elements. Landscape features in moderate condition. Capacity to accept well planned and designed change/ development of the type proposed.
Low	Landscape receptor of mixed character with a lack of coherence and including detracting or intrusive elements. Landscape features that may be in poor or improving condition and few that could not be replaced. Greater capacity to accept the type of change/ development proposed.

Magnitude of Landscape Effects

- 1.7 The magnitude of landscape effects is the degree of change to the landscape receptor in terms of its size or scale of change, the geographical extent of the area influenced and its duration and reversibility. The table below sets out the categories and criteria adopted in respect of the separate considerations of Scale or Size of the Degree of Change and Reversibility. The geographical extent and duration of change are described where relevant in the appraisal.

Scale or Size of the Degree of Landscape Change

Scale or Size of the Degree of Landscape Change	Definition
High	Total loss of or substantial alteration to key characteristics / features and the introduction of new elements totally uncharacteristic to the receiving landscape. Overall landscape receptor will be fundamentally changed.
Medium	Partial loss of or alteration to one or more key characteristics / features and the introduction of new elements that would be evident but not necessarily uncharacteristic to the receiving landscape. Overall landscape receptor will be obviously changed.
Low	Limited loss of, or alteration to one or more key characteristics/ features and the introduction of new elements evident and/ or characteristic to the receiving landscape. Overall landscape receptor will be perceptibly changed.
Negligible	Very minor alteration to one or more key characteristics/ features and the introduction of new elements characteristic to the receiving landscape. Overall landscape receptor will be minimally changed.
None	No loss or alteration to the key characteristics/ features, representing 'no change'.

Reversibility

Reversibility	Definition
Irreversible	The development would be permanent and the assessment site could not be returned to its current/ former use.
Reversible	The development could be deconstructed/ demolished and the assessment site could be returned to broadly its current/ historic use (although that may be subject to qualification depending on the nature of the development).

Visual

Sensitivity of Visual Receptors

- 1.8 Visual sensitivity assesses each visual receptor in terms of their susceptibility to change in views and visual amenity and also the value attached to particular views. The definition and criteria adopted for these contributory factors is detailed below.

Visual Susceptibility to Change

- 1.9 The susceptibility of different visual receptors to changes in views and visual amenity is mainly a function of; firstly, the occupation or activity of people experiencing the view at particular locations; and secondly, the extent to which their attention or interest may therefore be focussed on the views and visual amenity they experience.

Visual Susceptibility to Change	Definition
High	Residents at home with primary views from ground floor/garden and upper floors. Public rights of way/ footways where attention is primarily focussed on the landscape and on particular views. Visitors to heritage assets or other attractions whose attention or interest is likely to be focussed on the landscape and/ or on particular views. Communities where views make an important contribution to the landscape setting enjoyed by residents. Travellers on recognised scenic routes.
Medium	Residents at home with secondary views (primarily from first floor level). Public rights of way/ footways where attention is not primarily focussed on the landscape and/ or particular views. Travellers on road, rail or other transport routes.
Low	Users of outdoor recreational facilities where the view is less important to the activities (e.g. sports pitches). Travellers on road, rail or other transport where views are primarily focussed on the transport route. People at their place of work where views of the landscape are not important to the quality of the working life.

Value of Views

- 1.10 The value attached to a view takes account of any recognition attached to a particular view and/ or any indicators of the value attached to views, for example through guidebooks or defined viewpoints or references in literature or art.

Value of Views	Definition
High	A unique or identified view (e.g. shown as such on Ordnance Survey map, guidebook or tourist map) or one noted in literature or art. A view where a heritage asset makes an important contribution to the view.
Medium	A typical and/ or representative view from a particular receptor.
Low	An undistinguished or unremarkable view from a particular receptor.

Magnitude of Visual Effects

- 1.11 Magnitude of Visual Effects evaluates each of the visual effects in terms of its size or scale, the geographical extent of the area influenced and its duration and reversibility. The table below sets out the categories and criteria adopted in respect of the Scale or Size (including the degree of contrast) of Visual Change. The distance and nature of the view and whether the receptor's view will be stationary or moving are also detailed in the Visual Effects Table.

Scale or Size of the Degree of Visual Change	Definition
High	The proposal will result in a large and immediately apparent change in the view, being a dominant and new and/ or incongruous feature in the landscape.
Medium	The proposal will result in an obvious and recognisable change in the view and will be readily noticed by the viewer.
Low	The proposal will constitute a minor component of the wider view or a more recognisable component that reflects those apparent in the existing view. Awareness of the proposals will not have a marked effect on the overall nature of the view.
Negligible/ None	Only a very small part of the proposal will be discernible and it will have very little or no effect on the nature of the view.

Level of Effect

- 1.12 The final conclusions on effects, whether adverse or beneficial, are drawn from the separate judgements on the sensitivity of the receptors and the magnitude of the effects. This overall judgement is formed from a reasoned professional overview of the individual judgements against the assessment criteria.
- 1.13 GLVIA3 notes, at paragraphs 5.56 and 6.44, that there are no hard and fast rules with regard to the level of effects, therefore the following descriptive thresholds have been used for this appraisal:
- **Major**
 - **Moderate**
 - **Minor**
 - **Negligible**
- 1.14 Where it is determined that the assessment falls between or encompasses two of the defined criteria terms, then the judgement may be described as, for example, Major/ Moderate or Moderate/ Minor. This indicates that the effect is assessed to lie between the respective definitions or to encompass aspects of both.

Appendix 3- Illustrative Sketch Layout

Ref: 17746/1001A

- Contractors must check all dimensions on site. Only figured dimensions are to be worked from. Discrepancies must be reported to the Architect or Engineer before proceeding. © This drawing is copyright
- Reproduced from OS Sitemap® by permission of Ordnance Survey® on behalf of The Controller of Her Majesty's Stationery Office. © Crown copyright 2008. All rights reserved. Licence number 100007126.



- Key -**
- Existing Tree
 - Existing Hedgerow
 - Existing Development
 - Proposed Development
 - Proposed Private Drive
 - Proposed Adopted Road
 - Proposed Tree
 - Proposed Landscaped Buffer
 - Proposed Affordable Development

ACCOMODATION SCHEDULE

PRIVATE		
TYPE	BED	NO
2806	4B	2
1979	4B	1
1790	4B	2
1321	4B	2
1253	3B	1
1036	3B	2
998	3B	2
792	2B	8
TOTAL		20
AFFORDABLE		
3B5P	3B	2
2B4P	2B	4
603/486	1B	4
TOTAL		10
GRAND TOTAL		30

A LAYOUT UPDATED TO INCORPORATE LANDSCAPE AND ACCESS COMMENTS SA TF 14.12.2020

Revision	Description	Drawn	Checked	Date						
	Preliminary	■	Information	■	Tender	■	Construction	■	As Built	■

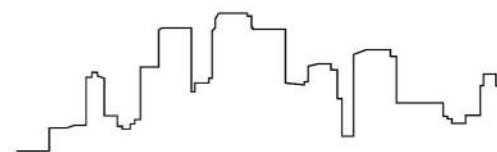

Woods Hardwick
Architects, Engineers and Development Consultants

Title **NEWTON FLOTMAN
IPSWICH ROAD - A140**

Details **ILLUSTRATIVE SKETCH LAYOUT**

Scale 1:1250@A3 Date NOV 2016 Drawn SA Chk TJF

15-17 Goldington Road
Bedford
MK40 3NH
United Kingdom
T. +44 (0)1234 268862
F. +44 (0)1234 353034
mail@woodshardwick.com
www.woodshardwick.com

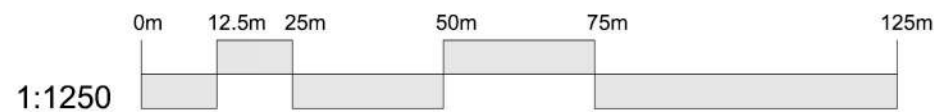

1:1250